

Model F, P & C Pig Valve Lifting Location and Handling Instruction

The information on this document is strictly confidential and may not be reproduced in any way without prior written permission of Argus
 PRINTED COPIES ARE UNCONTROLLED

1.0 PURPOSE

To outline the lifting and handling instructions for Argus Model F, P and C Pig Valves. As per API 6D, valves weighing 55 lbs. (25 kg) or greater require safe lifting instructions.

The Pig Valve center of gravity is measured relative to a reference point on the Pig Valve. This reference point is located on the axis of the valve bore, midway between the left and right flange faces. Note that this location is approximate and based on a standard Pig Valve configuration.

2.0 LIFTING INSTRUCTIONS

2.1 Only trained and/or credentialed personnel should perform crane lifts of Pig Valves. All local, site-specific safety requirements must be adhered to during the lifting operation.

⚠ Warning: Failure to adhere to the following guidelines may result in equipment damage, injury or fatality.

2.2 Refer to Table 1.0 for the approximate weight of the Pig Valves. The operator must ensure the load capacity of the sling meets or exceeds the weight of the Pig Valve.

2.3 Slings must be a minimum of 1" wide. As well, slings must be sufficiently long to create minimum 45 degree Sling Angle. Inspect slings for wear and/or damage. The operator must ensure slings are in good condition and suitable for use prior to beginning the lifting operation.

2.4 Wrap the sling around the neck area of the tailpieces on either side of the Pig Valve. Ensure sufficient length of the sling to give a sling angle of 45° or greater. See Figure 1.0 for details.

Note: Sling angle is measured from the horizontal to the leg of the sling.

2.5 Prepare the Pig Valve for lifting. Inspect the Pig Valve and surrounding area to ensure that there are no objects that could snag on the Pig Valve during the lift.

2.6 Connect the sling straps to the crane hook and lift the Pig Valve.

Note: Begin lift slowly, Pig Valve may tilt during the initial portion of the lift. Check to ensure that Pig Valve is level when lifted off the ground. If Pig Valve is not level, it may be necessary to rig another sling from the crane hook to balance the Pig Valve.

Specifications are Subject to Change Without Prior Notice – All Dimensions: inch [mm]

Created By: Malvin Pran

Created Date: 23 Jan 2023

Approved By:

Approved Date:

ECN No.:

Page: 1 of 2

Model F, P & C Pig Valve Lifting Location and Handling Instruction

The information on this document is strictly confidential and may not be reproduced in any way without prior written permission of Argus
 PRINTED COPIES ARE UNCONTROLLED

Table 1.0: Pig Valve Lifting Information

Valve Size	ASME Class	Pig Valve Weight ⁽¹⁾ (lbs.)	Lifting Point Distance (A) (inches)	Center of Gravity Location (inches)		
				X	Y	Z
2"	150	135	9.1	0	.2	.2
	300/600	145	10.1	0	.2	.2
	900	175	9.6	0	.1	.2
3"	150	190	10.0	0	.1	.2
	300/600	210	10.0	0	.1	.2
	900	230	10.3	0	.1	.2
4"	150	310	12.3	0	.1	.2
	300	325	12.3	0	.2	.2
	600	350	12.3	0	.2	.2
	900	370	12.5	0	.1	.2
6"	150	580	14.5	0	.2	.1
	300	620	14.5	0	.2	.1
	600	700	15.4	0	.2	.1

1) Values are approximate only. Pig Valve weight also referenced in TB-PV-008

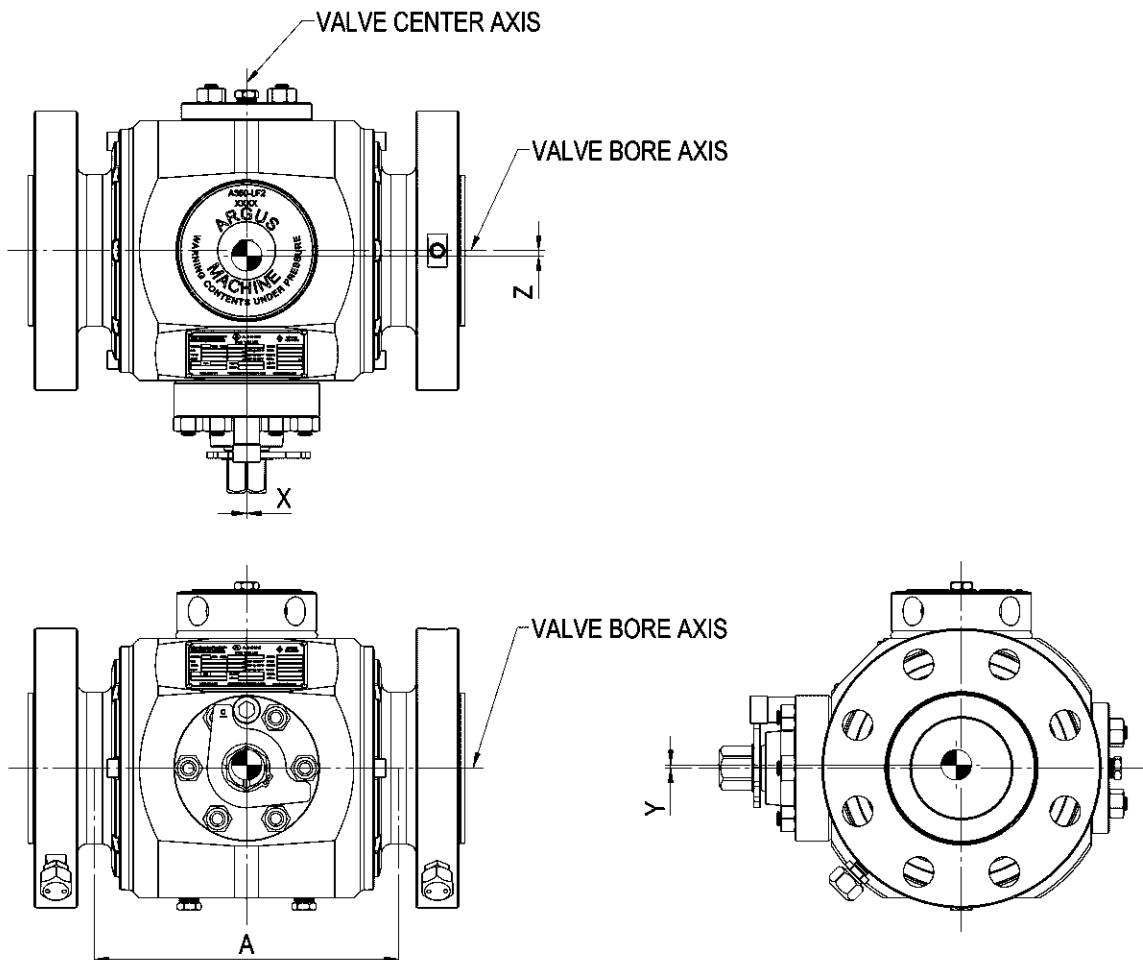

Figure 1.0: Pig Valve Center of Gravity