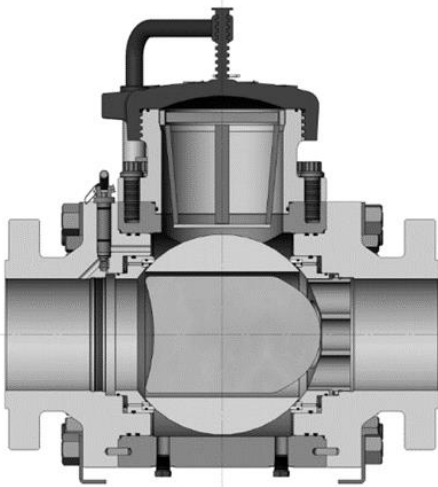

ARGUS MODEL D PIG VALVE – BULLET PIGS

The information on this document is strictly confidential and may not be reproduced in any way without prior written permission of Argus
 PRINTED COPIES ARE UNCONTROLLED

1.0 PURPOSE

To identify the maximum length and outer diameter of a pig that will function with an Argus Pig Valve.

2.0 BULLET STYLE PIGS & CUP AND DISK STYLE PIGS

BULLET STYLE PIGS (FOAM)		
<i>Valve Size</i>	<i>Maximum Pig Length</i>	<i>Maximum Pig OD</i>
6" (Model D)	9 1/2"	6 1/2"
8" (Model D)	12 5/8"	8 5/8"
10" (Model D)	15 1/4"	10 5/8"
12" (Model D)	17 11/16"	12 5/8"
14" (Model D)	19 7/8"	14 1/8"
16" (Model D)	21 13/16"	16 1/8"
18" (Model D)	24 1/2"	18 1/8"
20" (Model D)	27 1/4"	20 1/8"

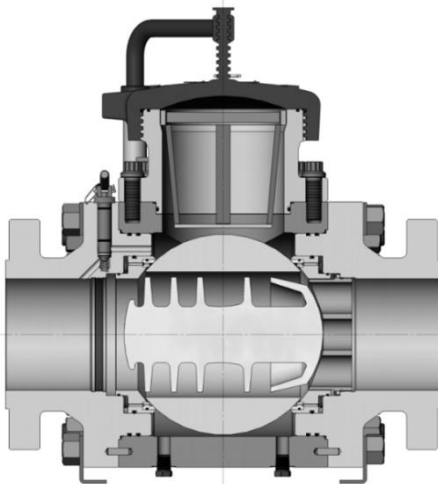

CUP & DISK STYLE PIGS (POLY / CAST)			
<i>Valve Size</i>	<i>Argus Pig Length (As Pictured)</i>	<i>Maximum Pig Length (Other)</i>	<i>Maximum Pig OD (Other)</i>
6" (Model D)	10 1/2"	9 1/2"	6 1/2"
8" (Model D)	14 1/4"	12 5/8"	8 5/8"
10" (Model D)	17 1/8"	15 1/4"	10 5/8"
12" (Model D)	20"	17 11/16"	12 5/8"
14" (Model D)	22 3/8"	19 7/8"	14 1/8"
16" (Model D)	24 5/8"	21 13/16"	16 1/8"
18" (Model D)	27 5/8"	24 1/2"	18 1/8"
20" (Model D)	30 5/8"	27 1/4"	20 1/8"

Specifications are Subject to Change Without Prior Notice – All Dimensions: inch [mm]

Created By: Jason Weiss

Created Date: 16 Sep 2008

Approved By:

Approved Date:

ECN No.: 02648

Page: 1 of 1