

PIG VALVE 14" & UP MODEL D

Installation, Operation, and Maintenance

USER MANUAL



ARGUS

Manufacturing Intelligent Solutions

Table of Contents

1.0	Scope	2
2.0	General.....	2
3.0	Applicable Standards.....	2
4.0	Safety.....	2
5.0	Handling and Storage	3
5.1	Handling	3
5.2	Storage	3
6.0	Installation.....	3
6.1	Inlet and Outlet Piping	3
6.2	Orientation	4
6.3	Mounting.....	5
7.0	Operation	6
7.1	Pig Launching.....	6
7.2	Pig Receiving.....	10
8.0	Maintenance	11
9.0	Injection Guidelines.....	12
9.1	Introduction.....	12
9.2	General	12
9.3	Injection Equipment	12
9.4	Cleaners.....	12
9.5	Lubricants	13
9.6	Sealants	13
10.0	Troubleshooting	14
11.0	Ordering Pig Valves & Pig Valve Service	15
11.1	Ordering Argus Pig Valves.....	15
11.2	Ordering Service for Argus Pig Valves.....	15
11.3	Contact Information.....	15

PIG VALVE

14" & UP MODEL D

1.0 Scope

Argus manufactures pig launching and receiving ball valves (Pig Valves) with flanged pipeline connections. This manual covers the installation, operation, and maintenance of the 14" and larger Argus Pig Valve model D.

2.0 General

Installation, operation, and maintenance of 14" and larger model D Pig Valves, shall comply with the procedures as described in this manual.

The Pig Valve is a double block and bleed valve which allows pigs to be inserted and removed, providing a safe and convenient alternative to the traditional method of pigging operations (with valves, tees, and traps). This is made possible by having independent upstream and downstream seats which isolate the body cavity from the upstream and downstream pressures when the valve is "CLOSED". An entry cap located at the top of the Pig Valve main body allows pigs to be inserted into and removed from the flow line when the valve is in the closed position. The standard Argus Pig Valve is designed for:

- Operating temperature range of -50°F (-46°C) to +250°F (+121°C).
- Sweet and sour service.
- Launching and receiving "Bullet", "Scraper", and "Spherical" type pigs.

3.0 Applicable Standards

The Pig Valve has been designed to meet the requirements of the following applicable standards:

- API 6D/ISO 14313††
- API 598
- NACE MR0175
- ASME B16.5, B16.34, B31.3, & Section VIII
- MSS SP-25

†Face to face dimensions for the model D exceed API 6D specifications (see "TB-PV-030" for details).

‡ Pig Valves with a "Left to Right" flow direction are in full compliance with API 6D and are marked with the API 6D Monogram. Pig Valves with a "Right to Left" flow direction are not marked with the API Monogram. Although these valves meet all other design requirements of API 6D, the "Right to Left" close direction is counterclockwise which does not meet the clockwise to close requirement specified in API 6D.

4.0 Safety

Many routine procedures are potentially hazardous if executed incorrectly or in unsafe conditions, particularly when toxic/flammable product is present. Caution must also be exercised when high temperature and/or pressure exist in the system. The routine of launching a pig and receiving a pig, while not complex, requires prudence to prevent personal injury and/or damage to the equipment. The procedures detailed in this manual must be followed closely.

Other precautions that must be observed are listed below:

- Pig Valves MUST be suitable for the service conditions.
- Always follow government and site safety regulations.
- Use appropriate safety equipment and clothing, including eye protection, when operating the Pig Valve.
- Stand clear when venting the main body cavity and removing the entry cap, to prevent exposure to spray, splatter, or spillage of any hazardous media which may be contained inside the valve.
- Always use Argus O.E.M. parts for service and repair.
- Never strike the Pig Valve or attached equipment.
- All accessories attached to the Pig Valve MUST be suitable for the service conditions.
- Never install or remove accessories from a Pig Valve that is under pressure.
- At least one vent valve MUST be installed in the Pig Valve before installation or operation.
- Never attempt to open or disassemble the closure while under pressure. Failure to relieve all pressure may lead to a violent expulsion of the contents.
- Never operate the closure while standing above the Pig Valve. Always open the closure from the side.

5.0 Handling and Storage

5.1 Handling

- Do not lift the Pig Valve by any part of the gear operator, entry cap or any other accessories attached to the Pig Valve. Use the attached lifting lugs whenever possible.
- Care should be taken to ensure that the Pig Valve is never subjected to impact or dropped during installation, storage, or handling.

5.2 Storage

- Pig Valves should be stored in a clean dry environment and should be left on shipping pallets or in original packaging prior to installation.
- All flange protectors should remain in place until installation of the Pig Valve.
- Pig Valves should be stored in the "FULLY OPEN" position (prevents damage to ball and seats).

6.0 Installation

6.1 Inlet and Outlet Piping

- Ensure the Pig Valve connections match (see nameplate on the Pig Valve) the nominal size and pressure rating of the inlet and outlet piping connections (e.g., 16" 600 ASME Class RF flanged connection).
- It is the responsibility of the piping designer to address vibration, thermal effects, line stresses, supports or any other factors that may occur due to field conditions. They shall also determine if a by-pass line is necessary to prevent pressure build-up of the flow line during the pigging operation.
- The inlet and outlet piping connections shall be aligned in such a manner to eliminate any additional stresses due to the Pig Valve installation.

6.2 Orientation

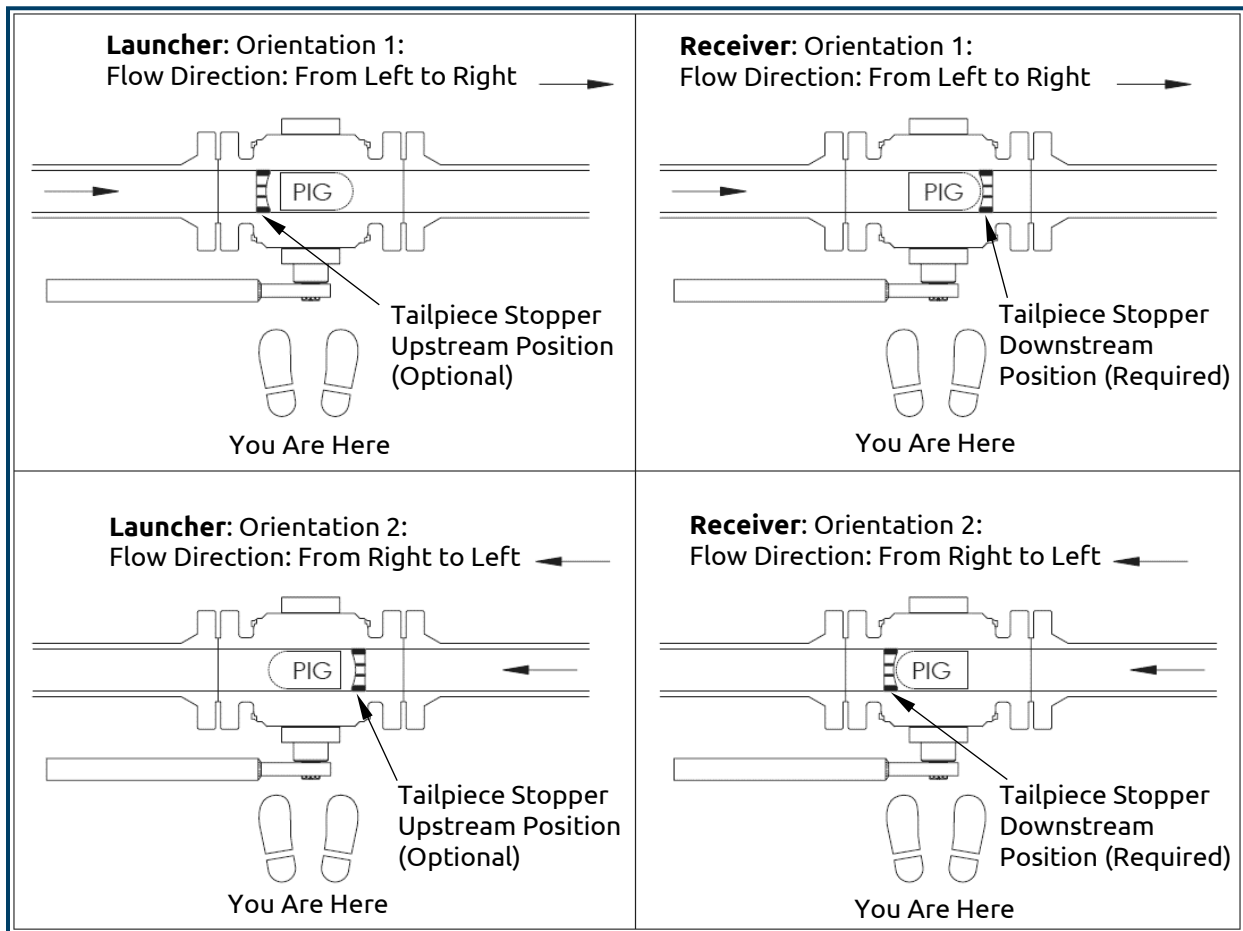

Figure 1: Pig Valve Orientation

- It is recommended to install the Pig Valves with the entry cap facing upward to avoid spillage of media during the insertion and removal of pigs. Argus standard Pig Valves **MUST** be installed with the entry cap facing upward with the flow being horizontal. Optional entry cap assemblies are available for vertical installation or where it is necessary to install the Pig Valve with the entry cap on its side.
- Pig Valves equipped with the Argus “Multi-Pig Launcher” (see technical bulletin “TB-ML-002”), **MUST** be installed with the “Multi-Pig Launcher” facing upward.
- Flow direction is indicated on the Pig Valve nameplate beside “FLOW”. When marked L←R flow is from the right side to the left side of the Pig Valve. When marked L→R flow is from the left side to the right side of the Pig valve.

Note: Pig Valve “launcher type” (Launcher) if equipped with an optional tailpiece stopper **MUST** be installed with the tailpiece stopper in the upstream tailpiece. Pig Valve “receiver type” (Receiver) **MUST** have the tailpiece stopper installed in the downstream tailpiece. Consult factory for non-standard pig stoppers.

6.3 Mounting

- Prior to installation and once the flange protectors have been removed, the Pig Valve should be inspected inside for foreign materials and the outside of the Pig Valve should be inspected for signs of tampering or damage.
- All sealing surfaces **MUST** be visually inspected to ensure they are free of foreign material or damage.
- Allow sufficient workspace around the Pig Valve for accessibility to allow for proper servicing and/or removal.
- The Pig Valve **MUST** be installed in the “FULLY OPEN” position.
- Ensure that at least one of the accessory ports in the Pig Valve has been equipped with a vent valve (see Figure 2 & Table 1).
- All flange studs and nuts **MUST** be tightened as recommended by industry standards.

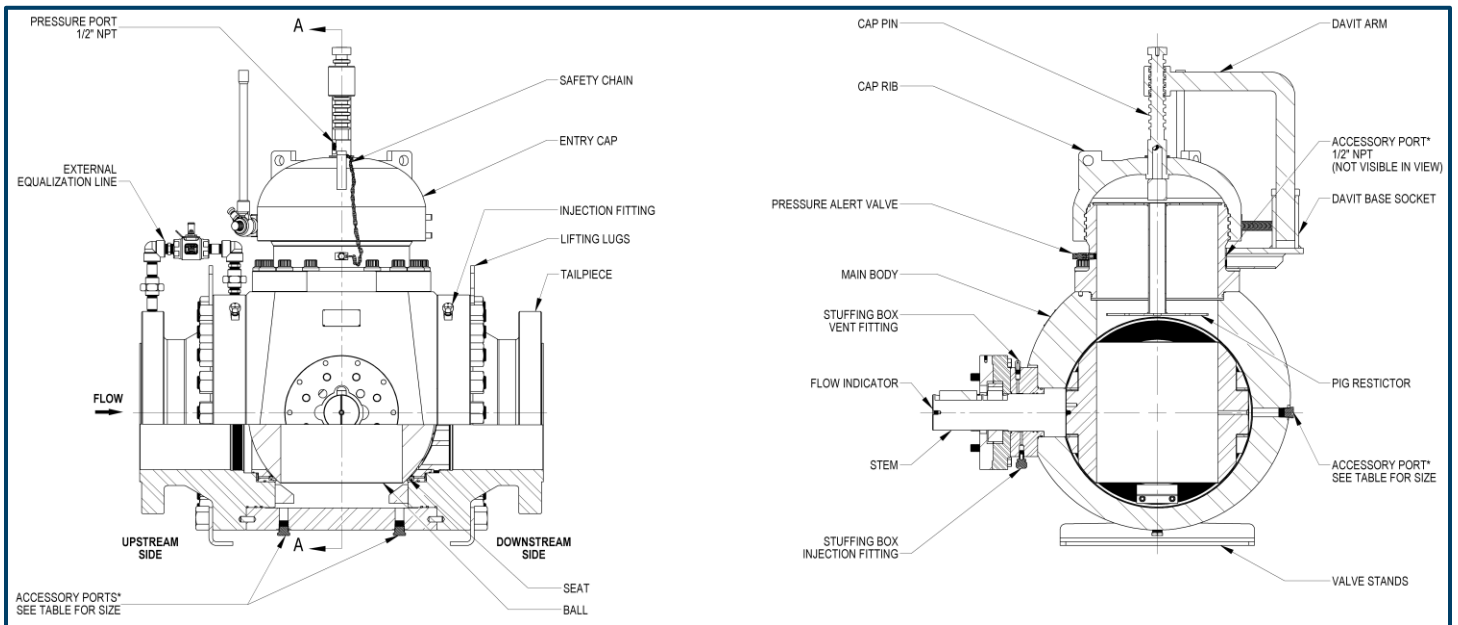

Figure 2: Pig Valve Model D c/w Pressure Alert Valve, External Equalization Valve

Table 1: Standard Accessory Port Size for Model D Pig Valves

Nominal Valve Size		Thread/ Pipe Size (NPT)
NPS	DN	
14"	350	1"
16"	400	1"
18"	450	1"
20"	500	1"

7.0 Operation

In the following section, it is assumed that the orientation of the Pig Valve is such that the rotating stem / gear operator is facing the field technician and the flow is “left to right”, as shown in Figure 1, for pig launching and receiving. Refer to Figure 1 – 7.

⚠ Caution:

- Do NOT leave the Pig Valve in a partially open position as this may damage the seats.
- Before closing the Pig Valve, the pipeline must be cleaned to purge all foreign materials, which may cause damage to the ball and/or ball seats (typical for new or repaired pipelines).
- Pigs must not exceed Argus maximum recommended dimensions (see technical bulletin “TB-PV-031”).
- Steel brush style pigs are NOT recommended. The wires may scratch the seat and/or ball sealing surfaces or come loose and wedge between the seat and ball.
- Use the supplied Argus Pig Valve entry cap lug wrench to open and close the entry cap. Other types of wrenches may damage the cap.

⚠ **Warning:** Do NOT use a metal-faced hammer to loosen the entry cap. Hammering can crack the entry cap. Failure to follow these instructions may result in serious injury or fatality.

7.1 Pig Launching

1. Open the by-pass valve (if present).
2. Close the Pig Valve (clockwise when flow is L→R and counterclockwise when flow is L←R). The “indicator” on the gear operator hub MUST read “CLOSED”.
3. Slowly open vent/drain valve, venting pressure and draining fluid from the Pig Valve main body cavity.
4. Ensure the equalization valve is set to the closed position (see Figure 3), preventing accidental operation during the pigging operation.

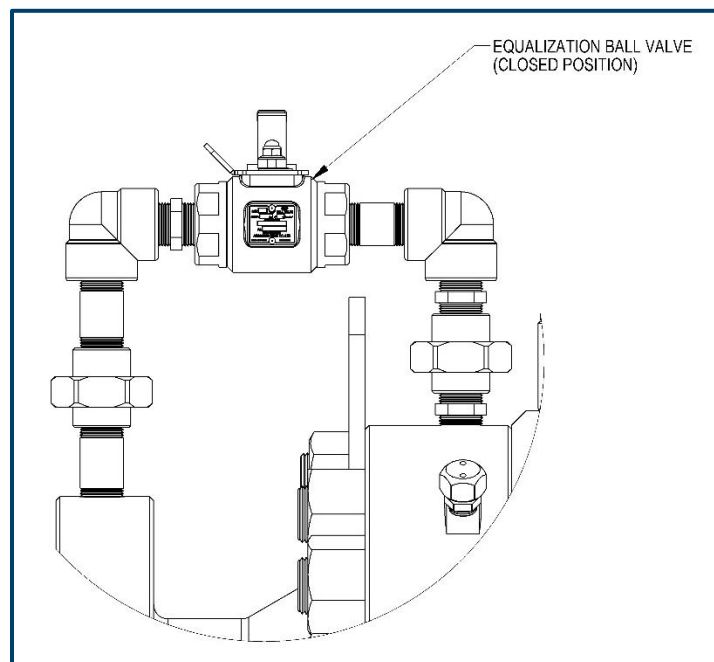

Figure 3: Argus External Equalization Line

5. Unscrew the pressure alert valve (PAV) stem, which is attached to the entry cap with the safety chain. Do NOT inadvertently loosen the pressure alert valve (PAV) body from the entry cap adapter. If pressure is still present it will be vented through the small hole on the side of the PAV indicating, it is unsafe to remove the PAV stem and to open the Pig Valve.

⚠ Warning: Do NOT remove the pressure alert valve stem if there is pressure present while unthreading. Failure to follow these instructions may result in serious injury or fatality.

Note: The pressure alert valve MUST NOT be used to vent cavity pressure.

6. Once the stem is removed from the PAV body place it and the chain on hook provided on top of the entry cap to ensure it will not catch on anything while unscrewing the entry cap.

⚠ Warning: Do not cut or break chain off from the entry cap because it will render this safety device useless. Failure to follow these instructions may result in serious injury or fatality.

7. Attach the closure actuator tool to the right davit post (see Figure 4) and use a ratcheting motion on the tool to slowly loosen the entry cap in a counterclockwise rotation. Observe the pressure warning groove area at the bottom of the threads on the entry cap (see Figure 5). If there is any media flowing from this area when the entry cap is loosened, immediately re-tighten the entry cap. Slowly open vent valve to vent remaining pressure and drain fluid from the Pig Valve main body cavity. If unable to vent all pressure from body cavity refer to Section 10.0 'Troubleshooting' in this manual.

⚠ Warning: Do NOT use a metal-faced hammer to loosen the entry cap. Hammering can crack the entry cap. Do NOT loosen the entry cap more than one-half turn until certain there is no leakage from the vent area. Failure to follow these instructions may result in serious injury or fatality.

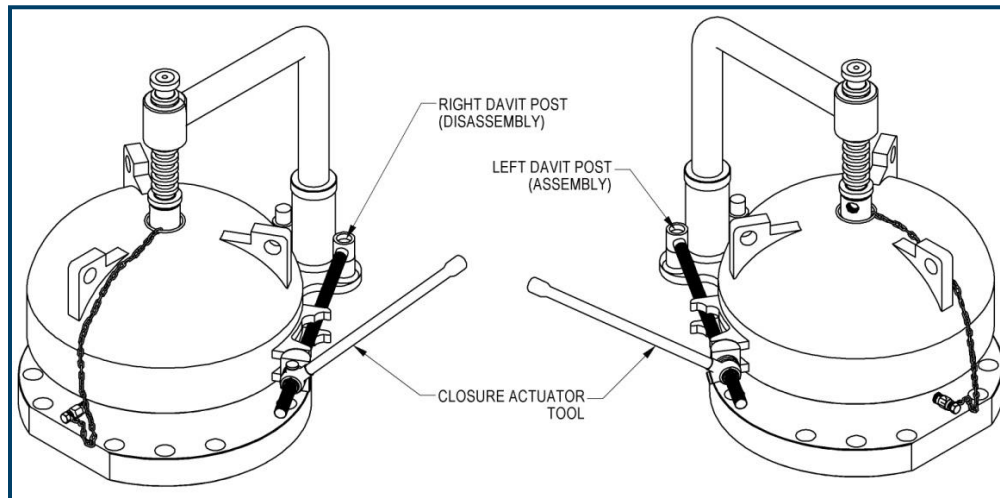

Figure 4: Closure Actuator Tool Positioning for Disassembling & Assembling of Entry Cap

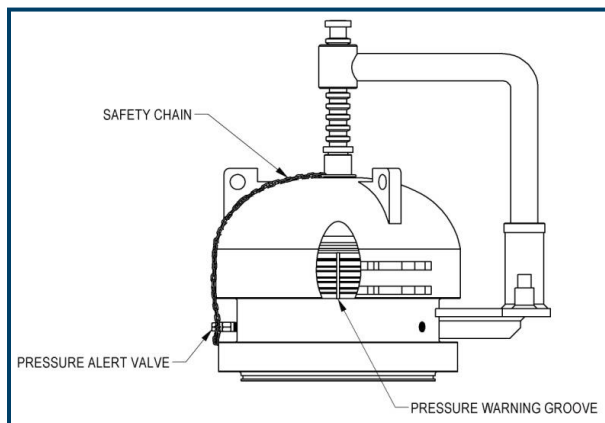

Figure 5: Pressure Warning Groove Location on Entry Cap

8. Once loose, unscrew the entry cap by hand, so that it clears the threads, and swing the cap 180° exposing the pig entry bore.
- ⚠ Warning:** Objects such as pigs or ice slugs can get trapped and/or ejected suddenly from the valve. Ensure that the entry cap is operated from the side of the cap, in front of the valve. Minimize direct exposure to the valve while the cap is open. Failure to follow these instructions may result in serious injury or fatality.
- ⚠ Caution:** It is important to prevent any foreign material from entering the Pig Valve main body cavity when entry cap is removed. Ensure the entry cap stays clean and free of damage when removed from Pig Valve.
9. Remove the pig restrictor from the valve bore (see Figure 2).
 10. Insert the pig into the Pig Valve. Bullet type pigs MUST be inserted nose down.
 11. Reinstall the pig restrictor into the valve bore.
- Note: The pig restrictor sits in a counter-bore located on top of the closure adapter. This prevents the pig restrictor from contacting the pig or the ball during operation of the valve. The pig restrictor MUST be replaced prior to closing the entry cap.
12. Before installing the entry cap, check that the sealing face and threads on the entry cap adapter are free of foreign material and burrs. Make sure the o-ring is not damaged (replace as required).
 13. Install the entry cap by rotating clockwise onto the adapter hub until unable to turn.
 14. Attach the closure actuator tool to the left davit post (see Figure 4) and use a ratcheting motion to slowly tighten the entry cap until metal-to-metal contact is made as indicated by alignment of the make-up arrows (see Figure 6).

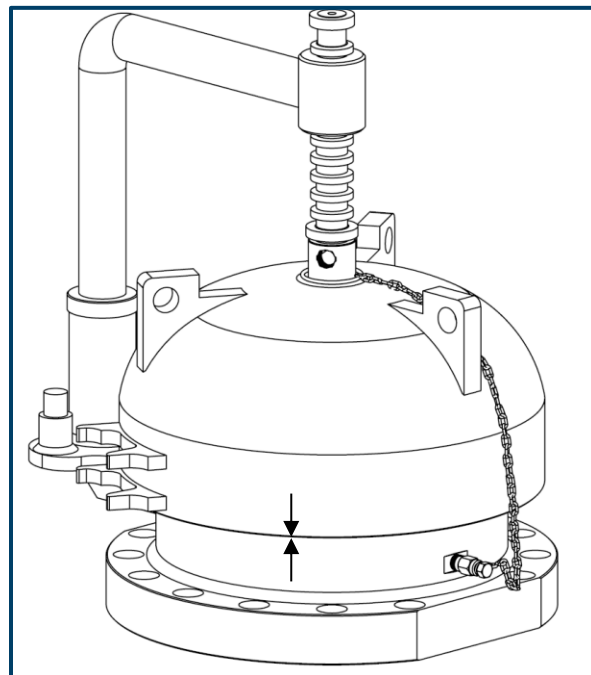

Figure 6: Entry Cap Make-Up Arrows

Note: The entry cap make-up arrows are stamped during assembly then painted white to increase visibility

- ⚠ Caution:** Do NOT over-tighten the entry cap past the alignment of the make-up arrows as excessive tightening can cause damage to the entry cap and/or the adapter.

15. Install the PAV stem by threading clockwise into body of the PAV.

⚠ Caution: The PAV valve is designed to be hand tightened; do NOT over-tighten the PAV valve stem as excessive tightening can cause damage to the PAV valve.

16. Close all vent/drain valves.

17. Equalize cavity pressure with the external equalization valve (see Figure 3). Turn equalization valve to the open position to energize cavity. Close the equalization valve once the valve cavity has been energized, which is usually indicated by an audible change in flow through the equalization valve.

18. Open the Pig Valve to launch the pig into the flow line. (Counterclockwise when flow is L→R and clockwise when flow is L←R). The "indicator" on the gear operator hub MUST read "OPEN".

19. Close the by-pass valve (if present).

Note: When equipped with a by-pass line, the by-pass shut-off valve may need to be closed prior to opening the Pig Valve and launching the pig. This will help build up sufficient pressure upstream of the pig to push it into the downstream piping. The extent of line contamination and the interference fit between the pig and flow line will determine whether this is necessary.

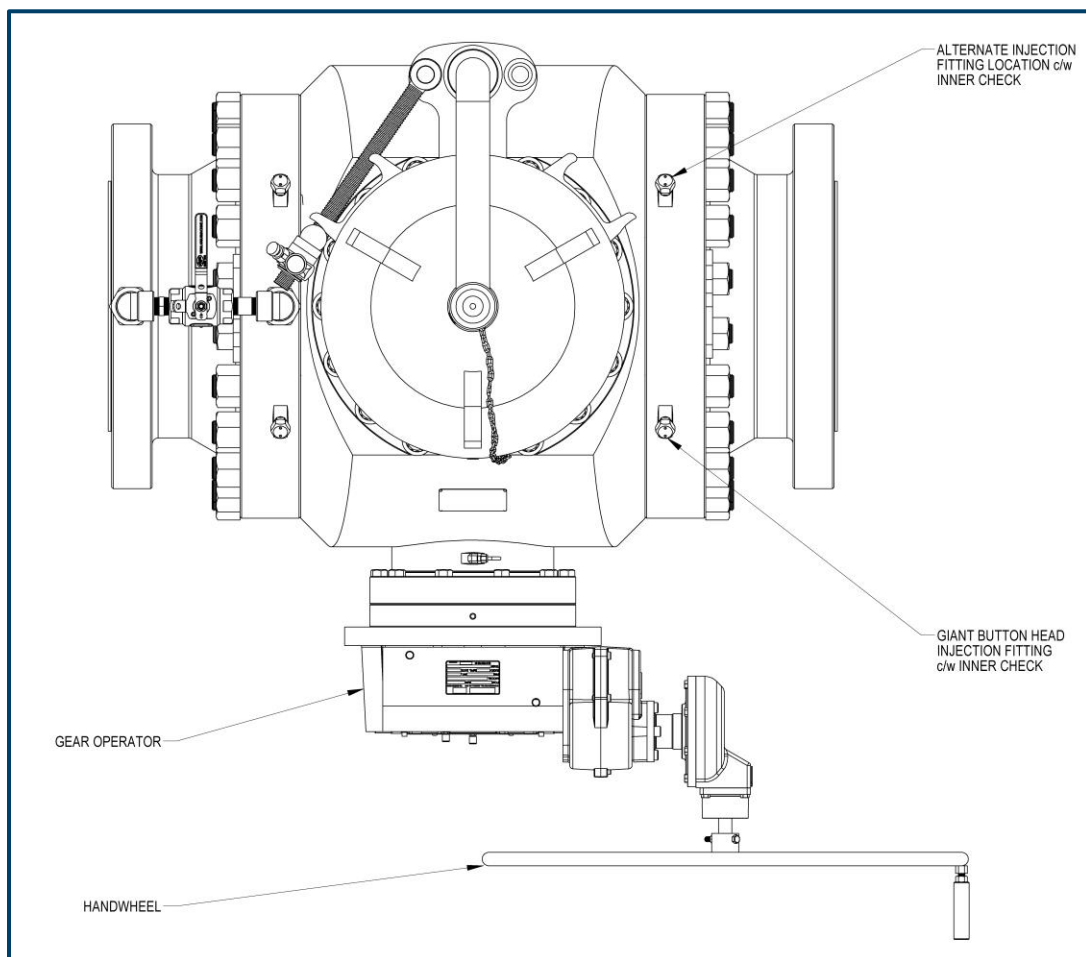

Figure 7: Top View of Argus Model D Pig Valve c/w Gear Operator

7.2 Pig Receiving

1. Once the pig has reached the Pig Valve, open the by-pass valve (if present).
2. Close the Pig Valve (clockwise when flow is L→R and counterclockwise when flow is L←R). The “indicator” on the gear operator hub MUST read “CLOSED”.
3. Slowly open vent/drain valve, venting pressure and draining fluid from the Pig Valve main body cavity.
4. Ensure equalization valve is in the closed position (see Figure 3), preventing accidental operation during the pigging operation.
5. Unscrew the pressure alert valve (PAV) stem, which is attached to the entry cap with the safety chain. Do NOT inadvertently loosen the pressure alert valve (PAV) body from the entry cap adapter. If pressure is still present it will be vented through the small hole on the side of the PAV indicating it is unsafe to remove the PAV stem and to open the Pig Valve.

⚠ Warning: Do NOT remove the pressure alert valve stem if there is pressure present while unthreading. Failure to follow these instructions may result in serious injury or fatality.

Note: The pressure alert valve MUST NOT be used to vent cavity pressure.

6. Once the stem is removed from the PAV body, place it and the chain on the hook on top of the entry cap to ensure it will not catch on anything while unscrewing the entry cap.

⚠ Warning: Do not cut or break chain off from the entry cap because it will render this safety device useless. Failure to follow these instructions may result in serious injury or fatality.

7. Attach the closure actuator tool to the right davit post (see Figure 4) and use a ratcheting motion on the tool to slowly loosen the entry cap in a counterclockwise rotation. Observe the pressure warning groove area at the bottom of the threads on the entry cap (see Figure 5). If there is any media flowing from this area when the entry cap is loosened, immediately re-tighten the entry cap. Slowly open vent/drain valve to vent remaining pressure and drain fluid from Pig Valve main body cavity. If unable to vent all pressure from body cavity refer to Section 10.0 ‘Troubleshooting’ in this manual.

⚠ Warning: Do NOT use a metal-faced hammer to loosen the entry cap. Hammering can crack the entry cap. Do NOT loosen the entry cap more than one-half turn until certain there is no leakage from the vent area. Failure to follow these instructions may result in serious injury or fatality.

8. Once loose, unscrew the entry cap by hand, so that it clears the threads, and swing the cap 180° exposing the pig entry bore.

⚠ Warning: Objects such as pigs or ice slugs can get trapped and/or ejected suddenly from the valve. Ensure that the entry cap is operated from the side of the cap, in front of the valve. Minimize direct exposure to the valve while the cap is open. Failure to follow these instructions may result in serious injury or fatality.

⚠ Caution: It is important to prevent any foreign material from entering the Pig Valve main body cavity when entry cap is removed. Ensure the entry cap stays clean and free of damage when removed from the Pig Valve.

9. Remove the pig restrictor from valve (see Figure 2).

10. Remove the pig from the Pig Valve.

11. Re-install the pig restrictor.

Note: The pig restrictor sits in a counter-bore located on top of the closure adapter. This prevents the pig restrictor from contacting the pig or the ball during operation of the valve. The pig restrictor **MUST** be replaced prior to closing the entry cap.

⚠ **Caution:** Should the pig be difficult to remove, do NOT use excessive side force. This may result in damage to the pig and/or ball. Pull the pig directly out of the Pig Valve without working it from side to side.

12. Before installing the entry cap, check that the sealing face and threads on the entry cap adapter are free of foreign material and burrs. Make sure the o-ring is not damaged (replace as required).

13. Install the entry cap by rotating clockwise onto adapter hub until unable to turn.

14. Attach the closure actuator tool to the left davit post (see Figure 4) and use a ratcheting motion to slowly tighten the entry cap until metal-to-metal contact is made as indicated by alignment of the make-up arrows (see Figure 6).

⚠ **Caution:** Do NOT over-tighten the entry cap as excessive tightening can cause damage to the entry cap and/or the adapter.

15. Install the PAV stem by threading clockwise into body of the PAV.

⚠ **Caution:** The PAV valve is designed to be hand tightened; do NOT over-tighten the PAV valve stem as excessive tightening can cause damage to the PAV valve.

16. Close all vent/drain valves.

17. Equalize cavity pressure with the external equalization valve (see Figure 3). Turn equalization valve to the open position to energize cavity. Close the equalization valve once the valve cavity has been energized, which is usually indicated by an audible change in flow through the equalization valve.

18. Open the Pig Valve (counterclockwise when flow is L→R and clockwise when flow is L←R). The "indicator" on the gear operator hub **MUST** read "OPEN".

19. Close the by-pass valve (if present).

8.0 Maintenance

- In climates where the flow line experiences freezing temperatures, drain any water or other media (which may solidify) from the Pig Valve thru the accessory ports on the bottom of the main body.

⚠ **Caution:** Media left in the Pig Valve that is susceptible to freezing may damage the Pig Valve.

- Lubricant can be injected into the Pig Valve to potentially increase the service life and reduce operating torque (see Section 9.0 Injection Guidelines). As part of a preventative maintenance program, it is recommended to lubricate the Pig Valve based on the frequency of operation and severity of service. The following are only guidelines as the required lubrication frequency is highly depended on the operation conditions:

- Lubricate the valve once every 30 cycles or once every two months, whichever comes first.
- Lubricate the valve whenever there is a noticeable increase in operating torque.
- Increase the frequency of lubrication during initial line commissioning and periods when higher levels of contaminants are present in the media.

- It is recommended to inspect the entry cap seal, sealing surface and the threads of the cap and adapter during the regular pigging operation (when the entry cap is removed). Replace seal and repair seal surface as required.
- Ball valves should not be immobilized for long periods of time. In instances where the Pig Valve is not used regularly, it is recommended that the Pig Valve be cycled every 2-3 months.
- In severe service, where media build up may be a concern, it is recommended to inject cleaners as required (see Section 9.0 Injection Guidelines).
- Whenever foreign matter exists on the closure threads or seal areas, remove the o-ring and clean the threads, seal areas and o-ring groove. Lubricate the threads and seal areas with an anti-galling lubricant such as lithium grease. Do not use silicone type lubricant. Do not fill the o-ring groove with lubricant.
- If cracks are visible on the cap or the adapter, replace the component.
- If reinstalling an o-ring, clean it and apply a light coating of lubricant to it, then install the o-ring in the groove.

9.0 Injection Guidelines

9.1 Introduction

Argus model D Pig Valves are equipped with seat injection ports and a stem injection port. These ports are used to inject cleaners, lubricants and sealants into the interface between the seat insert and the ball. Periodic injection of these cleaners, lubricants and sealants will reduce downtime, costly repairs and prolong the life of the Pig Valve. Cleaners and lubricants are especially recommended for severe service applications.

9.2 General

- Refer to manufacturers' instructions for use of injection equipment, cleaners, lubricants, and sealants.
- Do NOT inadvertently loosen the injection port body from the valve body when removing the injection port cover.
- Best results are achieved by injecting cleaners and/or lubricants while Pig Valve is in the "FULLY OPEN" or "CLOSED" position.
- Inject a sufficient quantity of cleaner, lubricant or sealant as required. A rule of thumb is to inject approximately 1-2 ounces per inch of valve size into each of the seat injection fittings

9.3 Injection Equipment

⚠ Warning: Read and follow all manufacturers' instructions for safe operation of injection equipment. Failure to follow these instructions may result in serious injury or fatality.

- Injection equipment is required to inject cleaners, lubricants and sealants into the Pig Valve.
- Recommend Sealweld® SuperGun or equivalent.

9.4 Cleaners

- Cleaners are used to clean critical seal surfaces and sealant passages by softening, flushing and removing old sealants, residual buildup and foreign particles (such as sand, debris, scales, etc.).
- Recommend Sealweld® Valve Cleaner Plus or equivalent.

9.5 Lubricants

- Lubricants are designed to protect critical seal surfaces against corrosion and flush out pipeline contaminants, as well as reduce operating torque requirements.
- Recommend Sealweld® Equa-Lube Eighty lubricant, Chemola Desco 622 lubricant/sealant, Jet-Lube Ezy-Turn #3 Arctic lubricant/sealant or equivalent.

9.6 Sealants

- ⚠ **Warning:** Pigging the flow line is NOT recommended after sealant has been injected into the Pig Valve (repair the Pig Valve before continuing pigging operation). Sealant may be used to ensure positive shut-off of the flow line when the Pig Valve is closed. Failure to follow these instructions may result in serious injury or fatality.
- Sealants are designed specifically for use with minor to severe leaking valves and emergency valve sealing operations.
- Recommend (minor leakage): Sealweld® Total-Lube #911 lubricant/sealant or equivalent.
- Recommend (severe leakage): Sealweld® Ball Valve Sealant #5050 sealant or equivalent.

10.0 Troubleshooting

Table 2: Problems & Possible Solutions

Problem	Possible Causes	Possible Solutions
Pig Valve won't open	<ol style="list-style-type: none"> 1. High torque 2. Media build up causing a sticking effect on moving parts 3. Media inside Pig Valve is frozen 	<ol style="list-style-type: none"> 1. Open pressure equalization valve Check equalization valve for blockage and repair as required 2. Inject valve cleaner and lubricant into ball seats (see Section 9.0 Injection Guidelines) 3. De-ice
Pig Valve won't close	<ol style="list-style-type: none"> 1. Foreign matter caught in ball and/or ball seats 2. Stops not set properly on gear operator 	<ol style="list-style-type: none"> 1. Remove Pig Valve from flow line and repair 2. Adjust stops on gear operator (See gear operator "Operating Manual")
Pig Valve cavity will not vent when in "CLOSED" position	<ol style="list-style-type: none"> 1. Foreign matter caught in ball and/or ball seats 2. Ball seats scratched 3. Equalization valve leaks 4. Stops not set properly on gear operator 5. Vent valve plugged 	<ol style="list-style-type: none"> 1. Inject cleaner and lubricant into ball seats (see Section 9.0 Injection Guidelines) 2. Remove Pig Valve from flow line and repair 3. Remove Pig Valve from flow line and repair 4. Adjust stops on gear operator (See gear operator "Operating Manual") 5. Isolate valve, vent the line and replace vent valve
Leakage around entry cap	<ol style="list-style-type: none"> 1. O-ring seal damaged 2. Seal surface damaged 3. Foreign matter on seal surface 	<ol style="list-style-type: none"> 1. Remove entry cap and replace o-ring seal 2. Remove entry cap, inspect seal surfaces, and repair as required 3. Remove entry cap and clean off foreign matter
Leakage around tailpiece	<ol style="list-style-type: none"> 1. Primary seal in tailpiece is damaged 2. Seal surfaces damaged 	<ol style="list-style-type: none"> 1. Remove Pig Valve from flow line and replace primary seal 2. Remove Pig Valve from flow line, inspect seal surfaces, and repair as required
Vent valve leaking	<ol style="list-style-type: none"> 1. Seats and/or seals damaged 2. Vent valve not closed 	<ol style="list-style-type: none"> 1. Isolate valve, vent the line and replace vent valve 2. Close vent valve

11.0 Ordering Pig Valves & Pig Valve Service

11.1 Ordering Argus Pig Valves

When Argus Pig Valves are ordered, the following information will be required:

- Model
- Size (NPS)
- ASME class pressure rating and flange type (e.g. 600 ASME Class RF)
- Pig launcher or pig receiver
- Flow direction (from “left to right” or “right to left”, with “rotating stem” facing user)
- Type of pig (Sphere or Bullet/Scraper)
- Quantity of pigs required
- Quantity of Pig Valves required
- Tailpiece pig stopper (optional on “Launchers”)
- Automatic or manual multi-pigging (optional, see “Multi-Pig Launcher” bulletin)
- Options or accessories

11.2 Ordering Service for Argus Pig Valves

When requesting service for Argus Pig Valves, please provide the following data to the Service Department:

- Size (NPS)
- Model
- ASME class pressure rating
- Serial number
- Reason for repair

Example:

- 16” Pig Valve
- Model D
- 600 ASME class
- S/N PV 01000

11.3 Contact Information

For ordering Argus Pig Valves or for service please contact us at:

Argus
Order Desk (Assembly Division)
5820 97 Street NW,
Edmonton, Alberta, Canada
T6E 3J1

Website: argusinnovates.com
Email: info@argusinnovates.com
Toll Free: 1.888.434.9451
Phone: 780.434.9451



ARGUS

Manufacturing Intelligent Solutions

1.888.434.9451
info@argusinnovates.com

argusinnovates.com