

PRESSURE SWITCH

MODEL AEF-HT/MBF-HT
Installation, Operation, and Maintenance



USER MANUAL



ARGUS

Manufacturing Intelligent Solutions

Table of Contents

1.0	Scope	2
2.0	General.....	2
3.0	Applicable Standards.....	3
4.0	Safety.....	3
5.0	Handling and Storage	3
5.1	Handling	3
5.2	Storage	3
6.0	Installation.....	4
6.1	General Notes	4
6.2	Installation Instructions.....	4
7.0	Operation	5
7.1	Operating Instructions	5
7.2	Pressure Setting.....	5
7.3	Microswitch Replacement	6
8.0	Maintenance	6
9.0	Troubleshooting	7
10.0	Relevant Documents	7
11.0	Contact Information	7

PRESSURE SWITCH

1.0 Scope

Argus manufactures high temperature pressure switches (automatic or manual reset) used to make or break an electrical circuit (an electric motor, a gas engine, etc.) upon sensing either 'high' or 'low' flow line pressure. This manual details the procedures for installation, operation and maintenance of Argus Pressure Switch Models 'AEF-HT' and 'MBF-HT' which are certified and marked for "Dual Seal" applications. These models are designed to ensure that the integrity of the switch is not compromised under continuous high process temperature.

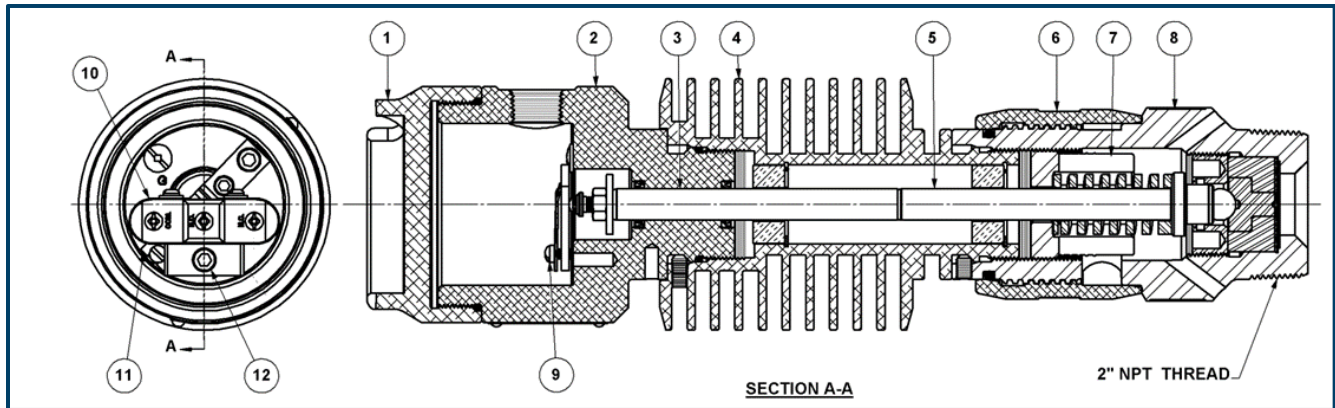

Figure 1: Argus High Temperature Pressure Switch (Automatic Reset - Model AEF-HT)

Table 1: Pressure Switch Parts – Model AEF-HT

Item	Description	Item	Description
1	Cap	7	Spring Adjustment Nut
2	Switch Housing	8	Bottom Sub
3	Stem Extension	9	Adjusting Screw, Leaf Spring
4	Heat Sink Extension	10	Microswitch
5	Stem	11	Leaf Spring
6	Access Collar	12	Locking Screw, Switch Block

2.0 General

Argus Pressure Switch (automatic or manual reset) is designed to make or break an electrical circuit (an electric motor, a gas engine, etc.) upon sensing either 'high' or 'low' flow line pressure. Installation, operation, and maintenance of Argus Pressure Switches shall comply with procedures as described in this manual. The Pressure Switch (automatic or manual reset) is designed for:

- Rated Maximum Operating Pressure of 5000 PSI (34,475 kPa).
- Allowable Temperature Ranges:
 - Ambient -50 °F (-46 °C) to +104 °F (+40 °C)
 - Switch Housing -50 °F (-46 °C) to +275 °F (+135 °C)
 - Process Media -50 °F (-46 °C) to +675 °F (+357 °C)
- Manufactured for sweet and sour service.

- Certified by CSA and have the NRTL/C mark signifying that they are suitable for use in Canada and the United States for Class I, Group D, Hazardous Locations (Division 1 and 2), Dual Seal.
- NEMA 4 and 7 enclosure.

3.0 Applicable Standards

Argus Type 'F' Pressure Switches are designed to meet the following standards:

- ABSA: CRN No. OF2161.2134
- ASME: B31.3
- CSA: C22.2 No. 30
- ANSI/ISA: 12.27.01
- NACE: MR0175

4.0 Safety

Many routine procedures are potentially hazardous if executed incorrectly or in unsafe conditions, particularly when toxic/flammable product is present. Caution must be exercised when high temperature and/or pressure exists in the system. Other precautions should be observed are listed below:

- Disconnect power supply before opening cap.
- Avoid getting moisture inside cap; keep all electrical components dry.
- Pressure Switches must meet the service requirements for the application.
- Always follow government and site safety regulations.
- Use of appropriate safety equipment and clothing is mandatory. Eye protection should be used when operating Pressure Switches.
- Never Strike the Pressure Switch or attached equipment.
- Do not stand on the Pressure Switch, or use it as a step.
- Any fittings or accessories must meet the service requirements for the application.
- Always use Argus O.E.M. parts for service or repair.

5.0 Handling and Storage

5.1 Handling

- Care must be taken to prevent the Pressure Switch from being damaged.

5.2 Storage

- Pressure Switches should be stored in a dry environment and should be left in the original packaging prior to installation.
- Thread protectors should remain in place until the Pressure Switch is to be installed.

6.0 Installation

6.1 General Notes

Pressure Switches are adjusted through a window in the Bottom Sub (it is not necessary to open the Cap when adjusting the pressure setting), hidden under the Access Collar.

Pressure Switches are normally supplied with a 2" NPT male threaded connection on the Bottom Sub. Other connections may be available on special request. Ask your Argus representative for special application connections.

6.2 Installation Instructions

1. Every Argus Pressure Switch is shipped in its own cardboard packaging carton and contains an Installation and Operation instruction sheet (Bulletin No. FM-PS-001). Remove this sheet and verify that the shipment description at the bottom of the page is correct. This contains information regarding the Pressure Switch Model Number, Serial Number, factory settings and pressure setting range. Please keep this instruction sheet for future reference.
2. Check female threads in the flow line fitting for any burrs, dirt, debris, or visible signs of damage before installing the Pressure Switch.
3. Remove thread protectors from the end of the Pressure Switch as well as the 1/2" NPT port (if applicable).
4. Check all threads for any signs of damage, dirt or debris.
 - ⚠ **Caution:** Do not attempt to install the Pressure Switch if there is any evidence of damage to any threads.
5. If any of the Pressure Switch threads are damaged, return to Argus for repair or replacement.
6. Apply a thin coat of a suitable thread sealant to male threads and hand-tighten bottom connection into the female flow line fitting.
7. When placing a wrench onto the bottom sub of the Pressure Switch, avoid contact with threads.
 - ⚠ **Caution:** Do not wrench on the aluminum access collar.
8. Tighten with wrench until proper make-up is achieved. If make-up is difficult to achieve, remove the Pressure Switch and check for any foreign matter, thread damage or galling and repeat above procedure.
9. Check the female (box) threads on the Switch Housing for damage, dirt or debris. In the event of serious damage please return the Pressure Switch complete with the instruction sheet and packaging carton to your Argus representative. Do not attempt to install the electrical conduit if there is serious damage to the female (box) threads on the Switch Housing.
10. Remove the Cap from the Switch Housing (use a screwdriver in the break-out slots provided in the Cap if necessary).
11. The male (pin) threads on the electrical conduit must be dry (do not use any lubricant, teflon tape or thread dope). Feed the electrical wires through the port and screw the conduit into the Switch Housing female (box) port hand-tight only.
12. Use a pipe wrench on the electrical conduit to tighten it into the female (box) port until proper make-up is achieved. If this appears to be difficult to achieve, remove the conduit and check for any foreign matter, thread damage or galling.

13. Attach electrical wires to the Microswitch as per Argus Wiring Instruction sheet (Bulletin No. TB-PS-002).

Microswitch Manufacturer's Recommended Torque (Maximum)

Mounting Screws.....3 in-lbs

Terminal Screws.....4 in-lbs

Panel Mount Bushing.....4-6 in-lbs

⚠ Caution: Tightening mounting screws above 3 in-lbs changes operating characteristics and increases the possibility of cracking the case. Applying excessive torque to the terminal screws when attaching the wires may cause damage to the Microswitch.

14. Install the Cap on the Switch Housing and hand-tighten only. When properly installed, the Cap should meet the shoulder on the Switch Housing. It is not necessary to wrench tighten the Cap to ensure a seal.

⚠ Caution: Do not over-tighten the Cap, as damage may occur.

15. Once installation is complete, the Argus Pressure Switch should be operated two (2) or three (3) times to verify the factory settings.

7.0 Operation

7.1 Operating Instructions

Once installation is complete, the Argus Pressure Switch will trip automatically.

- If it is an automatic reset switch, it will reset automatically when the pressure returns to within normal operating range.
- If it is a manual reset switch, it will reset when the operator pushes the reset button in top of the switch.

7.2 Pressure Setting

1. Rotate Access Collar counterclockwise until it hits the upper shoulder of the Switch Housing. This allows access to the port in the Bottom Sub. The slotted Spring Adjustment Nut should now be visible.
2. Using a flat blade (Standard) screwdriver, insert the blade into one of the slots and rotate the Spring Adjustment Nut to either increase or decrease the pressure setting as required. Rotating the Spring Adjustment Nut clockwise increases the set point, counterclockwise decreases the set point. Continue adjusting until the desired set point is achieved. Refer to the Argus Pressure Switch brochure for the available pressure ranges as per the model number.
3. Rotate the Access Collar clockwise until it hits the lower shoulder of the Bottom Sub. The access port should now be covered to keep out moisture and debris. (In conditions of severe vibration, the optional Vibration Lock may be purchased and used. Install the Vibration Lock with the pins in one slot of the Spring Adjustment Nut prior to screwing the Access Collar down).

⚠ Caution: Leave the Access Collar in the "down" position after adjustments have been completed.

7.3 Microswitch Replacement

If the Microswitch should fail during normal operation it can be easily replaced in the field using the following procedure:

1. Make sure that the power supply to the Pressure Switch is turned off.
2. Remove the Cap from the Switch Housing (use break-out slots in the Cap if required).
3. Disconnect all of the electrical wires from the Microswitch and tuck them out of the way.
4. Using a 3/16" T-Handle hexagonal wrench, loosen and remove the Switch Block Locking Screw.
5. Lift out the entire Microswitch sub-assembly.
6. Place the new Microswitch sub-assembly in the Switch Housing and tighten the Switch Block Locking Screw with the 3/16" T-Handle hexagonal wrench.

⚠ Caution: Do not over-tighten, as damage may occur.

7. Re-attach all the electrical wires to the Microswitch as they were before. (Refer to Argus Wiring Instructions Bulletin No. TB-PS-002).
8. If necessary, make adjustments to the Leaf Spring. Use a flat blade screwdriver to tighten the Leaf Spring Adjusting Screw clockwise until it shoulders. Turn the Adjusting Screw counterclockwise until you hear the Microswitch trip off (approximately 3 turns). Turn the Adjusting Screw 1 1/2 turns clockwise to set.
9. Install the Cap on the Switch Housing and tighten until the Cap shoulders with the Switch Housing.
10. Turn on the power supply to the Pressure Switch.

8.0 Maintenance

Argus recommends that a preventive maintenance program be implemented to ensure the longevity of the Argus Pressure Switch.

- Argus recommends that the operator periodically (quarterly) test each Pressure Switch to ensure that it is working properly.
- Tests may consist of a pressure test and verification of unit shutdown.
 - For a Pressure Switch that is set for increasing pressure the operator may close a valve downstream and check that the Switch trips off at the appropriate set point. If the set point is incorrect, the operator should adjust it to the original setting. (See Section 7.2 Pressure Setting).
 - For a Pressure Switch that is set for decreasing pressure the operator may close a valve upstream and check that the Switch trips off at the appropriate set point. If the set point is incorrect, the operator should adjust it to the original setting. (See Section 7.2 Pressure Setting).
 - The Pressure Switch may also be taken off the line and sent to an Argus Service Center for testing and adjustment.
- Visually check for excessive moisture in the Bottom Sub, by looking in the Access Port. If excessive moisture is present the Pressure Switch should be cleaned and serviced by Argus or one of their approved Service Centers.
- Argus also recommends that the Pressure Switch be tested after a service rig has done any work on the well site.

- The operator should visually check the Pressure Switch for any leaks or physical damage each time that he/she works on it. The Bottom Sub has two weep holes that will indicate when the internal gasket or diaphragm has failed. Ensure these weep holes are free of debris or foreign material. If excessive leaking (small amounts of moisture that is trapped inside the Bottom Sub may leak out normally) is evident the Pressure Switch should be replaced as soon as possible. The Pressure Switch may then be sent to an Argus Service Center for assessment and/or repair.
- Argus recommends that due to the sensitivity of the Microswitch the customer should consider carrying one (1) spare Microswitch sub-assembly in inventory for every ten (10) Pressure Switches in the field.

9.0 Troubleshooting

Table 2: Problems & Possible Solutions

Problem	Possible Causes	Possible Solutions
Switch does not trip at proper pressure, or does not trip at all	<ol style="list-style-type: none"> 1. Faulty electrical cable or connections 2. Pressure set point needs adjustment 3. Microswitch needs to be recalibrated 4. Microswitch failure 	<ol style="list-style-type: none"> 1. Check for damaged cable and/or loose connections 2. Adjust pressure set point using the Spring Adjustment Nut (see Section 7.2 Pressure Setting) 3. Adjust switch using the Leaf Spring Adjusting Screw (see Section 7.3 Microswitch Replacement) 4. Replace Microswitch (see Section 7.3 Microswitch Replacement)
Leaking from weep holes	<ol style="list-style-type: none"> 1. Pressure Switch gasket or diaphragm failure 	<ol style="list-style-type: none"> 1. Remove switch from line and send for servicing

10.0 Relevant Documents

- Pressure Switch (Type 'F') - Installation and Operation (FM-PS-001)
- Pressure Switch Wiring Harness Wiring Instructions (TB-PS-002)

11.0 Contact Information

For ordering Argus Pressure Switches or for service please contact us at:

Argus
 Order Desk (Assembly Division)
 5820 97 Street NW,
 Edmonton, Alberta, Canada
 T6E 3J1

Website: argusinnovates.com
 Email: info@argusinnovates.com
 Toll Free: 1.888.434.9451
 Phone: 780.434.9451



ARGUS

Manufacturing Intelligent Solutions

1.888.434.9451
info@argusinnovates.com

argusinnovates.com