

Pigging Previously Unpiggable Pipelines

Alisdair Blackley¹, Jason Weiss¹, Brett McNabb²

¹Argus, ²Apache Pipeline Products

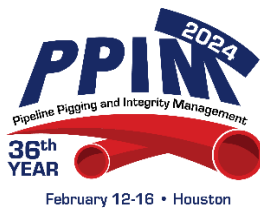

Pipeline Pigging and Integrity Management Conference

February 12-16, 2024



Organized by
Clarion Technical Conferences

Proceedings of the 2024 Pipeline Pigging and Integrity Management Conference.
Copyright ©2024 by **Clarion Technical Conferences** and the **author(s)**.
All rights reserved. This document may not be reproduced in any form without permission from the
copyright owners.

Abstract

The efficient and safe transportation of fluids through pipelines has been a cornerstone of modern infrastructure for decades. However, pipeline operators often face challenges when it comes to inspection, maintenance, and cleaning. These challenges are often addressed through pigging programs; however, a large portion of existing pipelines are considered "unpiggable." This is primarily due to pipeline size, complex geometry, or unique operational conditions. In recent years, the need to maintain and ensure the integrity of all types of pipelines, including those previously considered unpiggable, has grown significantly. The paper begins by defining what makes a pipeline "unpiggable" and delves into the common reasons for this classification. It will then explore the challenges associated with pigging previously unpiggable pipelines and some innovative solutions for pigging this type of infrastructure.

One of the primary challenges in pigging unpiggable pipelines is the development of suitable pigs and technologies. Traditional pigs are often designed for pipelines with standard dimensions and features. The paper discusses how the industry has responded to this challenge through the development of specialized pigs tailored to the unique requirements of unpiggable pipelines. This includes a summary of the development of various cleaning and product recovery solutions, such as foam pigs and swabbing devices, designed to address the unique challenges posed by unpiggable pipelines. Additionally, the paper includes information on the use of small, single-body inspection tools that the industry has developed to allow for in-line inspection in these applications.

Another significant challenge surrounds the changes required to update and modify existing pipelines to include the necessary pig launching and receiving infrastructure and remove or update features that hamper successful pig runs. The paper highlights the challenges associated with data collection on existing historical pipelines and some of the changes required to ensure successful pigging operations. Specifically, the paper outlines how the use of pipeline Pigging Valves and Multi-Pig Launchers can be used as an innovative alternative to traditional barrel-style pig launchers or receivers in previously unpiggable applications.

In addition to technological advancements, the paper delves into the operational, regulatory, and environmental considerations faced during pigging activities in unpiggable pipelines. These challenges include access to the pipeline, transportation and deployment of pigging equipment, high-frequency pigging, emissions regulations, and safety considerations.

In conclusion, pigging previously unpiggable pipelines presents a compelling challenge that demands innovative solutions. This paper provides an overview of the challenges faced and the technological advancements, operational strategies, regulatory compliance, and economic factors that must be considered. By understanding these complexities, pipeline operators and industry professionals can make informed decisions and effectively address the unique requirements of pigging previously unpiggable pipelines, ensuring the continued safe and efficient transportation of vital fluids in our modern infrastructure.

Introduction

The efficient and safe transportation of fluids through pipelines has been a cornerstone of modern infrastructure for decades [1]. However, pipeline operators often face challenges when it comes to the inspection, maintenance, and cleaning of pipelines. These challenges are often addressed through pigging programs; however, a large portion of existing pipelines are considered "unpiggable" for various reasons. This is primarily due to pipeline size, complex geometry, or unique operational conditions.

In recent years, the need to maintain and ensure the integrity of all types of pipelines, including those previously considered unpiggable, has grown significantly. According to the Pipeline and Hazardous Materials Safety Administration (PHMSA), it is estimated that 40 percent of the world's pipelines are difficult to pig or deemed "unpiggable" [2]. The ability for pipeline operators to pig is increased in transmission pipeline segments, as legislation has historically driven increased inspection of these types of pipelines and infrastructure. Past surveys conducted by the Interstate Natural Gas Association of America (INGAA) of its members indicated that 64 percent of the members' mileage is piggable [3]. In 2021, the Pipeline and Hazardous Materials Safety Administration (PHMSA) and the Department of Transportation (DOT) significantly expanded the scope of safety and reporting requirements for more than 400,000 miles of previously unregulated gas gathering lines with the publication of their "Final Rule" [4], [5]. As a result, investment into making these pipelines piggable has increased significantly.

Additionally, industry is currently undergoing a "changing of the guard" accelerated by the retirement of many highly experienced Pipeliners over the last decade, exacerbated by trends associated with the 2020 COVID-19 pandemic [6]. The result is an increased demand within the industry to provide information on best practices that may not have been formally passed on to new pipeline designers and operators.

The paper begins by outlining features that have historically made a pipeline unpiggable and delve into the common reasons for this classification. It then explores the challenges associated with pigging previously unpiggable pipelines and some innovative solutions for pigging this type of infrastructure from the perspective of pig selection, alternative technologies, and industry advancements. Throughout, the paper outlines some specific operational considerations when pigging in previously unpiggable lines.

Pigs for Unpiggable Pipelines

The "piggability" of a pipeline primarily derives from the geometry of the various components used to construct the line. Obstacles negatively impacting piggability include valves, diameter restrictions, piping diameter changes, and the physical ability for entry and removal access points for the pig into and out of the pipeline to be pigged. An ideal case for pigging would be a perfectly straight line with no changes in internal geometry. However, in reality, pipelines are required to transport fluids through various environments. They must navigate existing natural or man-made obstacles, requiring the line to deviate from this fictional ideal geometry. For the pig to successfully navigate these features, it must be manufactured considering many different variables.

Diameter Changes or Diameter Restrictions

Minor changes in a line's internal diameter (ID), such as a change in pipe schedule, can often be easily navigated by appropriately sizing the Pig's outside diameter (OD) to ensure a suitable interference with the pipe wall is provided. Based on available reference data, the range of interference for various elements of the pig can be between zero and ten percent oversized from the line ID [7]. Based on industry experience, a range of between three and five percent over-the-line ID is proposed for urethane-designed elements.

Significant changes in piping wall thickness, or changes of line diameter entirely, can lead to situations where the pig may either lose contact with the line ID and stall out or become stuck, blocking the line, due to the high interference between the pig and the pipeline ID. Specific areas of concern for pipeline diameter changes, as is the case with "dual-diameter" pipelines, include valves, changes in piping wall thickness or schedule, use of multiple pipe diameters, and when using varying pipeline materials. See Figure 1 and Figure 2 for a typical example of a multi-diameter utility pig showing large, flexible discs used in the oversized line section and smaller, more rigid discs sized for the smaller line section.

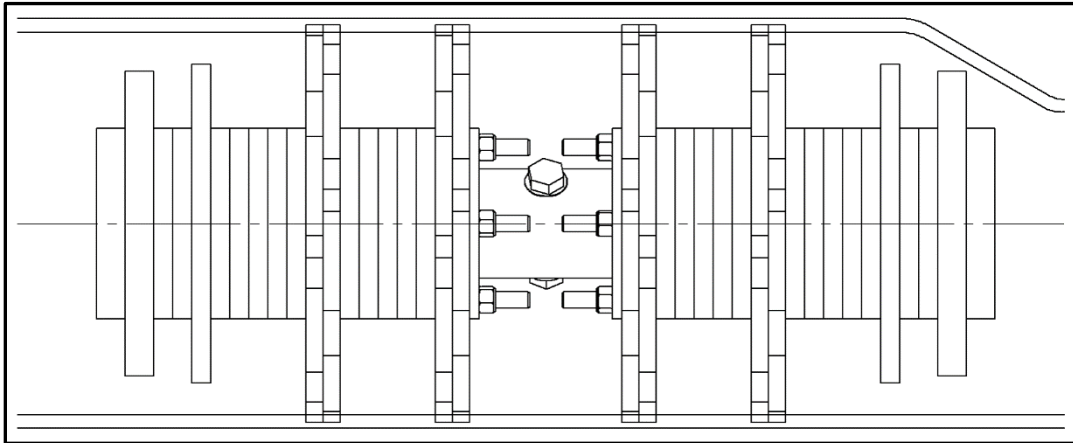

Figure 1 - Typical Multi-Diameter Utility Pig (Large Piping)

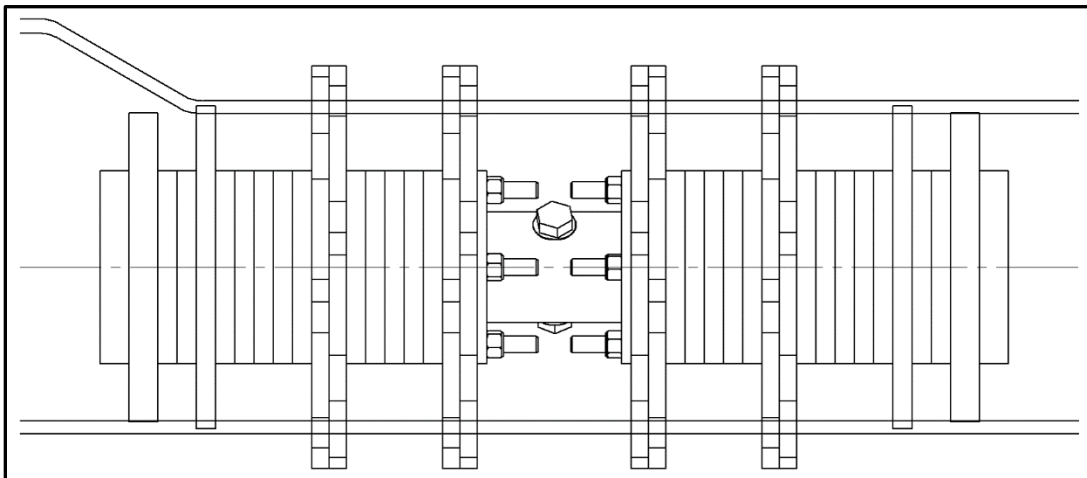

Figure 2 - Typical Multi-Diameter Utility Pig (Small Piping)

The growing trend to use polymer or high-density polyethylene (HDPE) pipe materials can also be a challenge as these gathering lines commonly combine steel and polymer sections, which can lead to significant line ID changes when combined. With the global HDPE market expected to grow at a 5.1 percent compound annual growth rate (CAGR) from 2023 to 2032 [8], the challenges associated with multi-diameter pipelines will also grow. Both the nominal line dimension and maximum and minimum internal diameters of line features must be understood when designing systems. The transition from steel piping at pipeline and valve risers often requires special consideration and even a larger nominal HDPE pipe size to minimize the variance in ID. Transitions between HDPE Pipe and HDPE fittings can also contain blunt shoulders or unfavorable upset conditions. To combat significant diameter changes when present, standard operational pigs will not suffice, and customizations, such as the presence of butterfly discs and collapsible cups, are often required. These components allow the pigs to navigate the diameter changes and provide the desired level of cleaning.

Bends

Bends in pipelines can pose a challenge to pig navigation and are common areas where pigs can become lodged or stuck. Existing pipelines can be classified as unpiggable if the compilation of piping bends in the system contains small radius bends or if the bend geometry is unknown [9]. In general, the radius of a bend is referenced by the radius of the bend from its centerline in terms of the nominal diameter of the pipe (D). A "short-radius elbow" or "tight radius bend" is the smallest radius customarily used and is a $1D$, or its radius is equivalent to the nominal diameter of the pipe. The "long-radius elbow" or $1.5D$ and a $3D$ bend are more commonly used. For example, using an 8" pipe, a $3D$ bend would have a radius of $3 \times$ the nominal diameter, or 24". See Figure 3 for an overview and visualization of commonly used factory pipe bends.

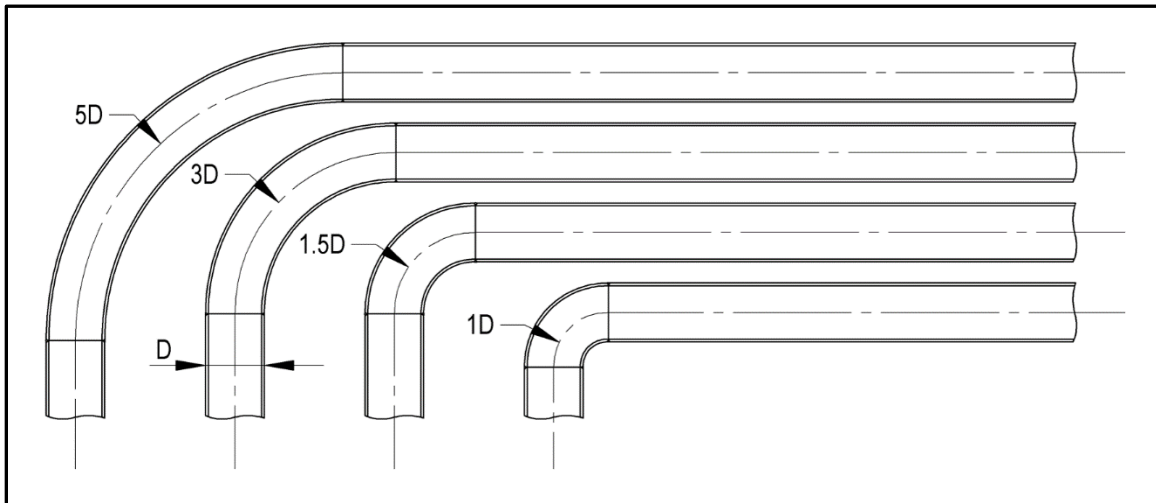

Figure 3 - Common Factory Pipe Bends

The minimum recommended bend radius is dependent on the type of pig being run, as cleaning and utility pigs will more easily navigate smaller bends as compared to a more complex inline inspection (ILI) tool, also known as "intelligent pigs" or "smart pigs," requires. For cleaning pigs, bends need a minimum of $1.5D$ with a sufficient distance between the bends to allow for easy navigation. For a typical piggable system with allowance for more flexibility with ILI tools, traditional guidance or industry norms would specify a minimum of $10D$ for ≤ 4 " piping, $5D$ for 6" to 12" piping, and $3D$ for > 12 " piping systems [7].

Pipelines are regularly designed or modified to include smaller radius or mitred bends, and often, piping systems include adjacent or back-to-back bends due to space constraints. To tackle these challenges and meet the varying cleaning requirements, many types of cleaning pigs are available, including Sphere (ball) Pigs, Foam (bullet) Pigs, Solid Cast Urethane Pigs, and Steel Mandrel Pigs. When 1D elbows are present, pig selection is typically limited to sphere or possibly soft-density foam pigs. Solid cast urethane and harder-density foam-style pigs will be able to navigate 1.5D bends. Typically, the length and components of a steel mandrel pig need to be carefully considered during the engineering phase, as usage with 1.5D bends is not recommended. Figure 4 shows a steel mandrel pig with significant interference or "hung up" transitioning to a 1.5D long-radius bend. The second image (right) in Figure 4 shows the same pig easily navigating a 3D piping bend. If the bend restriction information is unknown or unavailable, all operators should cautiously assume that 1.5D bends may be present during pig selection.

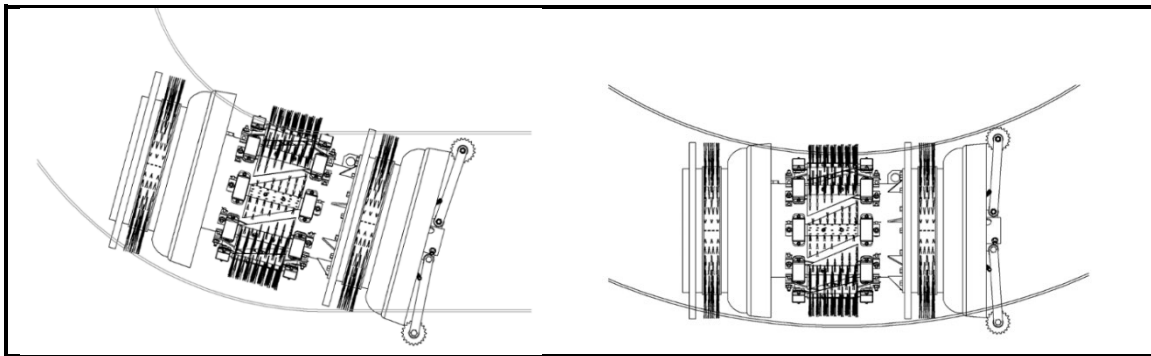

Figure 4 - Typical Cleaning Steel Mandrel Pig in 1.5D (left) & 3D (right) Piping Bends

Line Connections

Various piping connections, including inlets and outlets, can also lead to geometry that can cause a pig to stall or become stuck, creating an unpiggable pipeline. Examples of such features include Tees, Laterals, Crossovers, and Wyes. Pig design and selection become critical to navigating these features, and information on existing piping design is not always available.

Both the overall length of the pig and the maximum effective seal length become critical factors when navigating the fittings or line connections. Sphere or "ball type" pigs can be useful as they will go around almost any bend type and can be launched in more simplistic pig launchers; however, they also offer the smallest overall length and have minimal effective seal length in contact with the pipeline, making their cleaning or purging ability highly ineffective as compared to other pig types. As a result, sphere pigs are most susceptible to media bypass and can easily stop or become lodged in piping outlets; Figure 5 depicts this scenario in both a reduced and full unbarred tee.

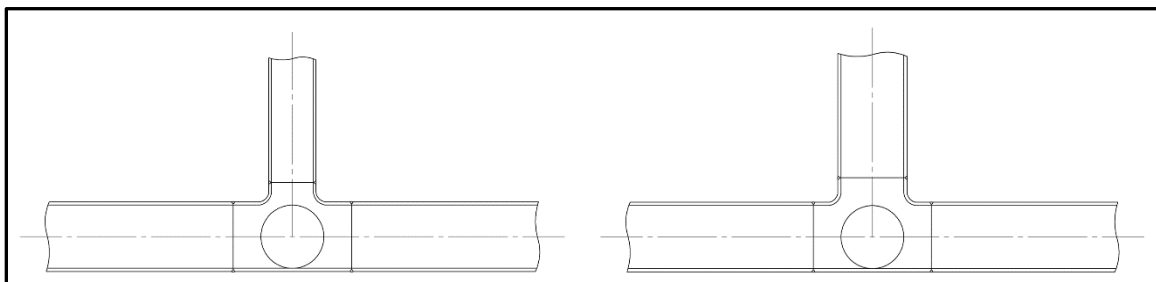

Figure 5 - Example of Sphere Pig with Bypass in Tee (Reduced & Full)

Choosing more rigid pigs, such as cast urethane versus foam construction, along with maximizing the overall length of the pig, will provide increased resistance to the pig nosing itself down an unintended outlet like a large lateral or unbarred tee. Figure 6 depicts a foam pig in a full-diameter tee; often, existing pipelines are not designed for pigging, allowing some pigs to become 'lost' down unintended outlets. In contrast, maximizing the effective seal length of the pig will enable the pig to traverse large outlets like a full-diameter outlet on a tee or lateral without the potential of bypass and a possible stall. Figure 7 shows an optimized urethane cup/disc pig as it easily navigates pipeline tees, barred or unbarred. The durometer or hardness of urethane pigs can be increased to provide increased rigidity or more aggressive cleaning and decreased if higher flexibility is desired, allowing for tighter bends or decreasing pipe IDs.

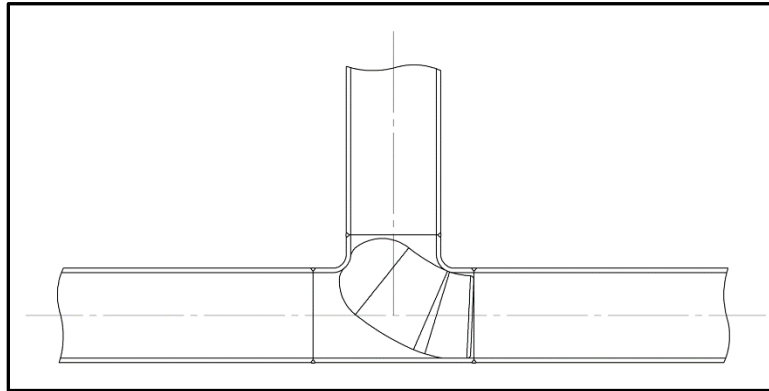

Figure 6 – Typical Foam Bullet Pig in Unbarred Tee

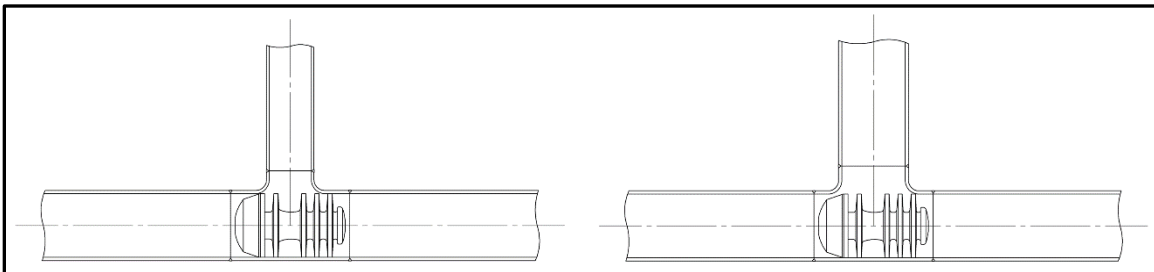

Figure 7 - Example of Urethane Cup/Disc Pig Traversing an Unbarred Tee (Reduced & Full)

Pig selection is critical when navigating lateral or wye-style outlets, as these fittings are naturally intended to divert flow. Figure 8 shows a custom steel mandrel pig, designed with multiple cups to ensure the pig will not only traverse the oversized lateral but also maintain numerous contact points or seals needed to ensure the pig does not stall in a low-pressure gas application.

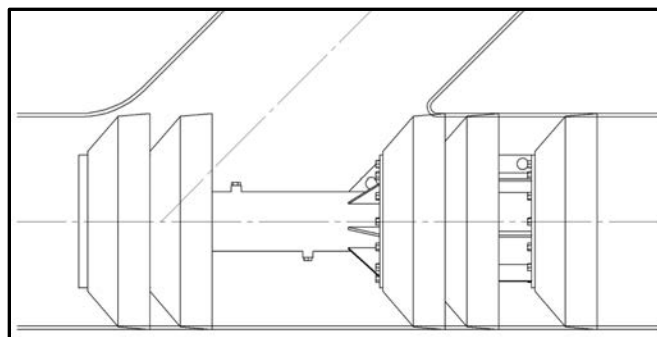

Figure 8 - Example of a Pig Traversing Lateral

Wye fittings are becoming more popular in gathering networks and are typically used to allow media from two pipelines to converge into a single pipeline. Wyes capable of pigging are typically fabricated from components or forged in a single piece and can be either asymmetric or symmetric with differing convergence angles. Figure 9 depicts two forged piggable wyes with an included convergence angle of 22.5° (left) and 30° (right). It should be noted that pigs can only run or navigate the wyes in one direction, as shown. Depending on the design, wyes can have very different characteristics which impact the pig selection to ensure piggability. The span (S) will impact the length of the pig required, as the larger the span, the longer the effective length of the pig is necessary to maintain the seal to the pipe ID as the pig traverses the wye. The nose geometry of the pig is another feature which enables the pig to navigate the wye better as it passes through the feature.

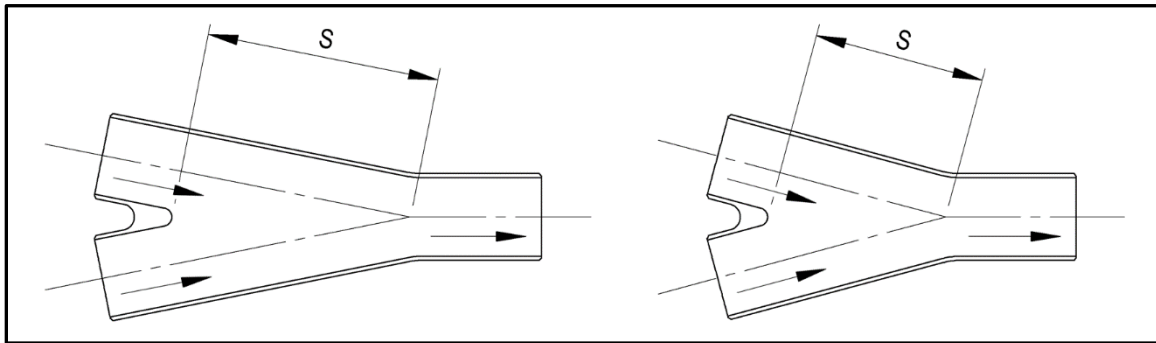

Figure 9 - Typical Piggable Wye Fittings

Unpiggable In-Line Inspection

Effective pigging operations on existing pipelines necessitate a thorough understanding of historical pipeline data, including information on the pipeline's construction, materials, and past maintenance activities. Challenges lie in acquiring accurate and comprehensive historical data, which is often dispersed and may not meet current data standards. In the case of many unpiggable pipelines, this can require an initial inline inspection of the pipeline. Fortunately, numerous short-body single-module inline inspection tools have been developed, allowing operators to collect detailed data on pipelines that were previously deemed unpiggable [10], [11], [12]. With these innovative solutions becoming more prevalent across the industry, the need for extensive pigging facilities to send and receive ILI tools within gathering pipeline networks is significantly reduced or even removed entirely.

Summary of Recommendations for Pig Design and Selection

When endeavoring to recommend any pig for an unpiggable situation, it is paramount to undertake a risk assessment and design the tool suitable for the existing line parameters. It is generally advised that the following be evaluated before proceeding:

- What, if any, records are available for existing line components
 - Smaller radius bends (1D and 1.5D)
 - Known obstructions in the line.
 - Other typical unpiggable line features, as previously discussed.
- Can any previous/recent inline inspection (ILI) or Magnetic Flux Leakage (MFL) data be consulted for updated line data?
- Does the operator have the capacity to manage any debris in the line that will subsequently be swept through the line?
 - i.e. Separators or slug catchers after the pig receiver

- Flow conditions – optimal pigging speeds of 3-5 fps are recommended [13].
- Are there proper pigging facilities available for launching and receiving pigs?

After the above points have been considered, the pig manufacturer has several different options & pig designs to suit their application:

- Butterfly Discs increase flexibility or performance in dual-diameter lines, shown in Figure 10.
- Sealing elements, such as those shown in Figure 11, with custom OD or thickness to decrease the component's interaction with the inside pipe wall.
- Customizable brush options to increase aggressiveness in removing buildup from pipe ID, Figure 12, are available in carbon, stainless steel, nylon trim material, and custom trim lengths.
- Removable bypass ports to slow the pig down in high-flow conditions.
- Customizable lengths to fit multi-pig launchers or pigging valves.
- Different durometer options are readily available to suit specific needs [14].

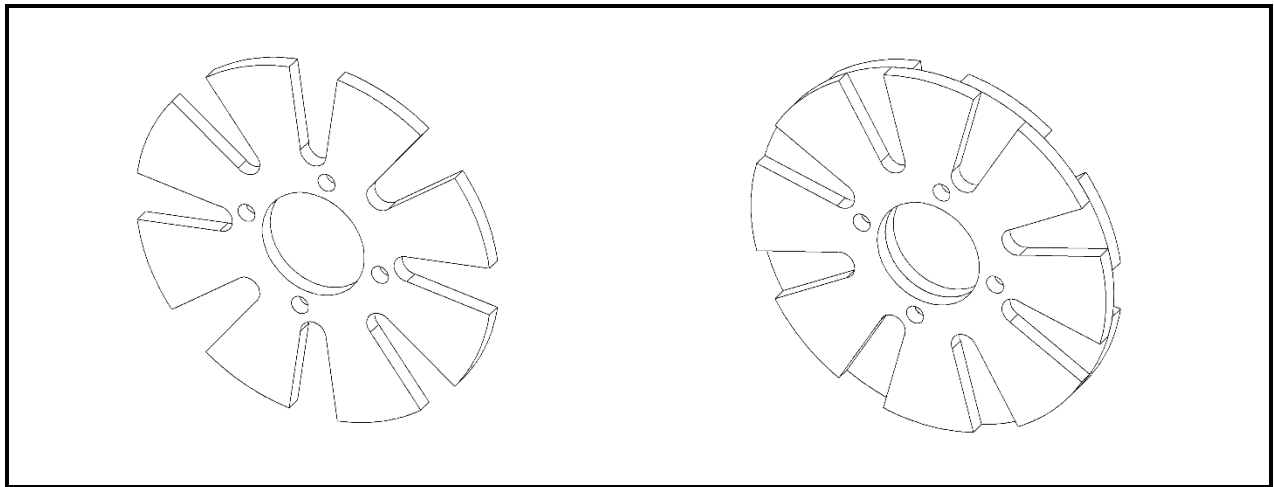

Figure 10 - Single Butterfly (Left) & Paired Butterfly (Right) Discs

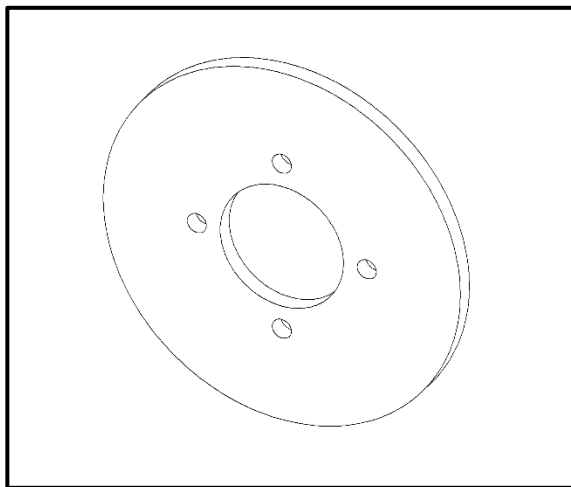

Figure 11 - Sealing Disc

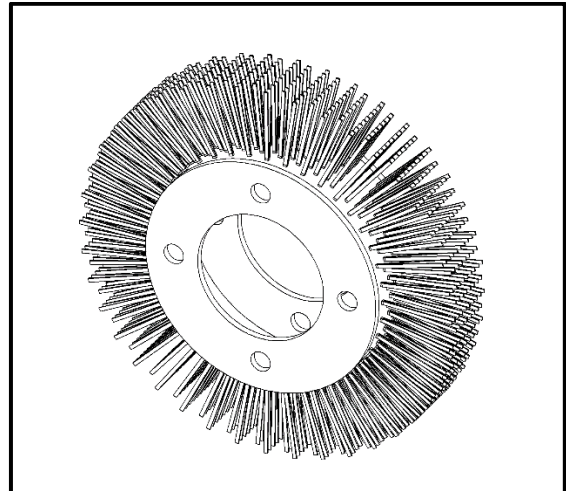

Figure 12 – Brush Option for Pig

Operational Considerations

The need to pig pipelines that were historically not pigged arises from several factors, including an evolving understanding of the importance of regular maintenance, inspection, and cleaning for all pipeline types and the evolving landscape of media transported by pipelines. These changes have been additionally driven by regulations aiming to reduce the environmental impact of line breaks and venting [15], high-profile safety incidents, and the inspection of aging infrastructure. Additionally, liquid condensate, produced at a wellhead, is increasingly growing in demand and value. This has led to increased gas drilling focused on natural gas liquid (NGL) rich plays. Condensate production in Canada increased by over 265 percent from 2013 to 2017 alone [16]. Advances in pigging technologies have been driven by these requirements, along with the economic and safety benefits of routine pigging.

All these changes have resulted in the need for pigging lines that were never intended or designed for pigging, requiring operators to consider various alternatives to update and modify existing infrastructure. In the United States, this has included the recent inclusion of over 400,000 miles of pipelines, under Federal oversight [4], which may consist of requirements for emissions reduction, corrosion control, inspection, and testing, among other requirements [17]. All of this requires consideration of the operational aspects related to the necessity of pigging such pipelines, challenges in updating and modifying existing infrastructure, environmental factors, high-frequency pigging implications, safety concerns, and introducing innovative alternatives to traditional pigging methods.

Updating Existing Infrastructure

Access to the inside of the pipeline is ultimately required to facilitate the insertion and subsequent removal of the pig. However, this can be highly hazardous, depending on the line contents, temperature, and operating pressures. Traditionally, a conventional or "barrel-style" pig launcher or receiver has been employed. These types of infrastructure consist of a fabricated, oversized barrel with associated lines for venting and draining line media, bypass lines, and a "kicker" line to divert line flow to send the pig. See Figure 13 for an overview of a typical configuration. These types of launchers are familiar to most operators; however, they require an enormous footprint and involve up to twenty steps to safely and correctly launch the pig [7], depending on the specific configuration.

Modifying existing pipelines to accommodate pigging operations requires identifying and, in some cases, removing or updating features that hinder successful pig runs. This involves addressing issues mentioned previously, such as tight bends, irregularities in diameter, or outdated fittings that impede the seamless movement of pigs through the pipeline. In many cases, appropriate pig selection and design, as discussed above, can allow an unpiggable pipeline to be pigged. However, there may be features discovered that necessitate excavation and replacement.

Pipelines and piping systems previously not designed to be pigged generally do not have provisions for launching or receiving pigs. These scenarios require an operator to consider several factors associated with retrofitting the line, including upfront costs, space requirements, ease of operation, site accessibility and environmental impact. Alternative launching solutions, such as pig launching and receiving ball valves or pigging valves, as shown in Figure 14, can result in a significantly less complex system, reducing upfront modification costs and footprint. Additionally, these systems have been demonstrated to result in reduced emissions and have been recommended by the Office of

Enforcement and Compliance for the United States Environmental Protection Agency (EPA) as an engineering solution to reduce emissions [15].

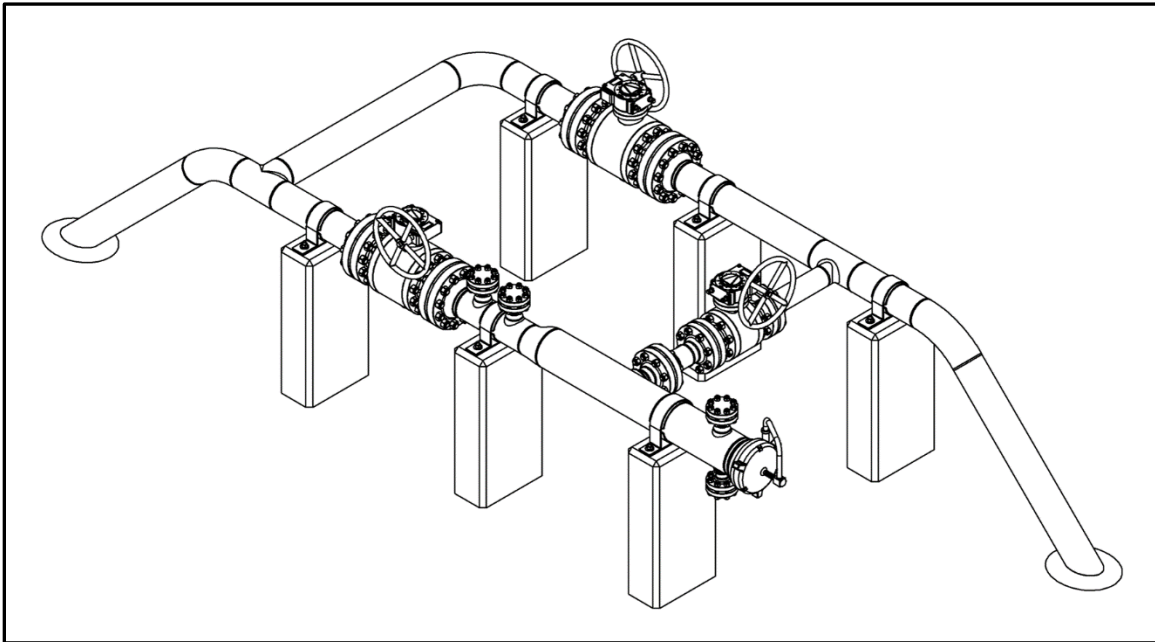

Figure 13 – Basic Configuration for Conventional Pig Launcher/Receiver

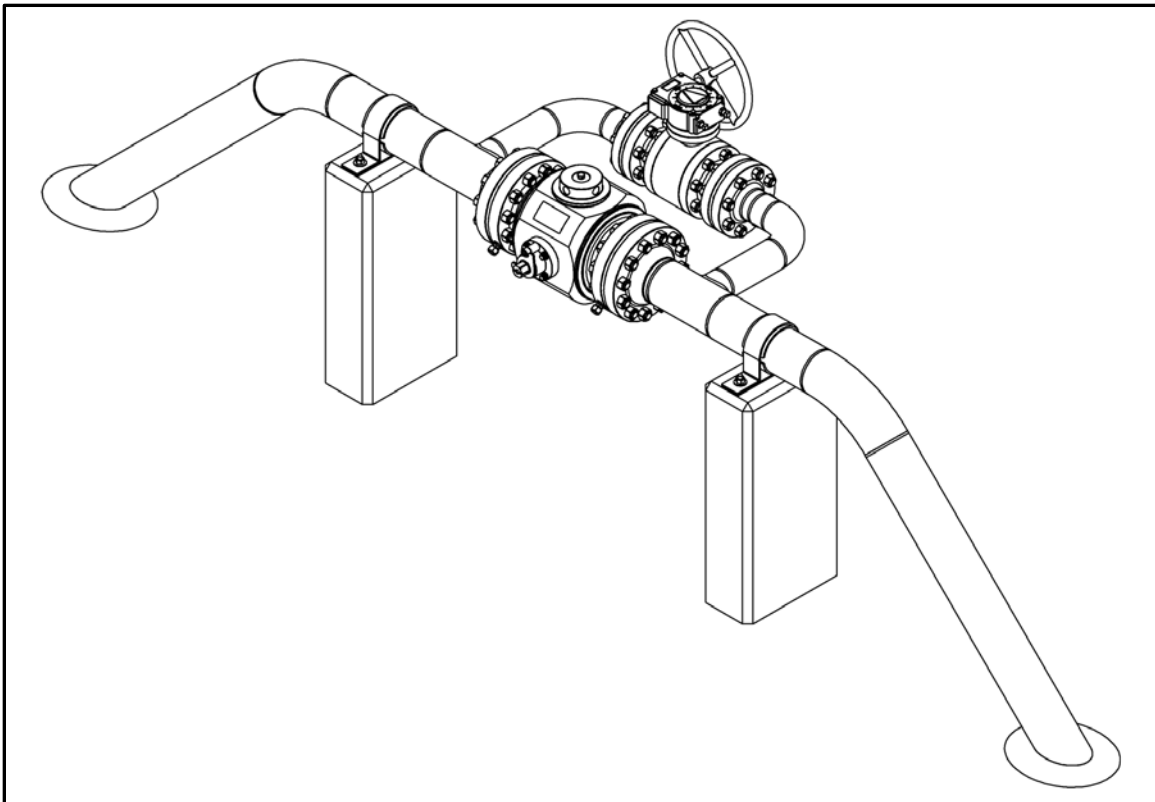

Figure 14 – Basic Configuration for Pig Valve (Launcher/Receiver)

Environmental Considerations

Existing unpiggable pipelines may be situated in challenging environments or locations with limited access. Overcoming these geographical and logistical constraints is a substantial challenge. Implementing access solutions, such as remote monitoring or robotic technologies, becomes crucial for effective pigging operations. Such solutions can include pig signalers, pressure and temperature monitoring, and leveraging packaged pigging stations to reduce on-site construction and logistical costs. This is notable as transporting and deploying pigging equipment to unpiggable pipelines, which are often still online, demands specialized logistics. The development of compact and easily deployable pigging systems is essential. Addressing challenges related to equipment size, weight, and adaptability to diverse terrains is imperative for successful pigging campaigns.

EPA investigations have identified Clean Air Act (CAA) non-compliance caused by unauthorized and excess emissions from depressurizing pig launchers and receivers in natural gas gathering operations [15]. As environmental sustainability gains prominence, emissions reduction becomes critical in pigging operations. This involves minimizing the environmental impact of pigging activities, updating infrastructure to reduce emissions associated with pig launching and receiving, and adhering to emissions regulations to ensure responsible and sustainable pipeline maintenance. Specifically, many jurisdictions have passed strong legislation requiring operators to reduce emissions associated with all pipeline operations significantly. Section 114 of the PIPES Act of 2020 requires operators to address eliminating hazardous leaks and minimizing the release of natural gas [18].

Operational Safety

Safety is paramount in all pipeline operations, especially when pigging pipelines. Pigging operations inherently involve potential exposure to pressurized line media. Additionally, as these operations can be viewed as "routine," operators are at an increased risk of neglecting to acknowledge the severity of the hazards. As such, pigging operations have been associated with historical safety incidents that stem from failing to recognize and assess the risks associated with pigging [19]. Addressing these safety concerns involves comprehensive risk assessments, adherence to strict safety protocols, and implementing emergency response strategies.

Additionally, personnel transportation has been found to account for a disproportionate percentage of safety incidents within the Oil & Gas industry [20]. This highlights a further need for operators to address safety during the transport of field personnel to pigging stations, critically in remote and high-frequency applications. Regardless of pig launching or receiving site location, robust safety measures are critical to safeguard personnel, equipment, and the environment.

High-Frequency Pigging

Natural gas is transported from production wells to processing plants through networks of gathering pipelines. While transporting this gas through gathering pipeline systems, the gas often experiences a temperature drop or pressure change that causes the hydrocarbons and other components to condense to a liquid phase [15]. These natural gas condensates often fall out and accumulate in low-lying piping, such as river crossings and other lower-elevation piping segments. The accumulation of these liquids in the gathering pipelines effectively reduces the effective cross-sectional area of the piping, impeding the flow of natural gas. The presence of these liquids, if left, will choke production, and can increase the likelihood of internal pipe corrosion.

To maintain gas flow, optimize production, and increase integrity through corrosion mitigation of the gathering pipelines, operators push these liquids out of the low elevations and down the pipeline by pigging. Determining the correct timing to run a pig can be a science of monitoring flow rates and pressure anomalies. This can be critical in ensuring downstream processes and equipment (separators, compressors, etc.) remain within a suitable operational range. The timing, or frequency, of pigging, can also be more of an art, based around the availability or access of personnel to complete the pigging operations. By increasing the frequency of pigging, the liquids present within the line can be minimized, improving overall line performance. With the US market recently hitting a high for natural gas production [21], the number of lines expected to increase in liquids production will likely continue to grow. In some circumstances, the practical challenge with increased pigging is that the remoteness of wellsite's or the limited direct access available to gathering systems can effectively make pigging a challenge. The feasibility of doing the pigging or the associated costs make the infrastructure "unpiggable."

Innovative alternatives, such as Pipeline Pigging Valves (Pig Valves) and Multi-Pig Launchers, offer strategic solutions to challenges in pigging previously unpigable pipelines. A basic configuration for a typical multiple sphere pig launcher is found in Figure 15. When operators are looking for enhanced cleaning capabilities and increased sweeping effectiveness, alternatives such as a vertical Argus-style multiple pig launcher, can launch urethane cup-and-disc style cleaning pigs, as shown in Figure 16. These technologies enable controlled and efficient pig launching and receiving, minimizing the need for extensive modifications to the existing pipeline infrastructure.

Automated multiple pig launchers provide additional solutions to operators challenged with the burden of remote pigging or high-frequency pigging, as that technology allows for up to eleven (11) pigs to be pre-loaded by an operator and then controlled and conveniently launched automatically without further human intervention. Multiple pigging systems also offer significant gains through significant reductions in associated operational costs and decreased greenhouse gas emissions [22].

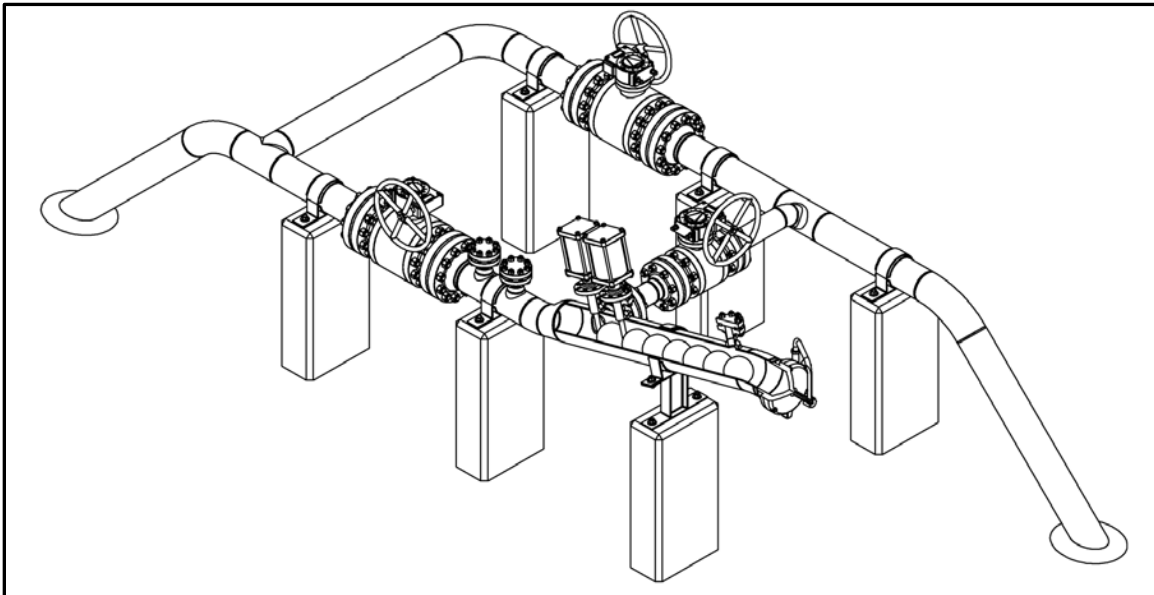

Figure 15 - Basic Configuration for Typical Multiple Sphere Pig Launcher

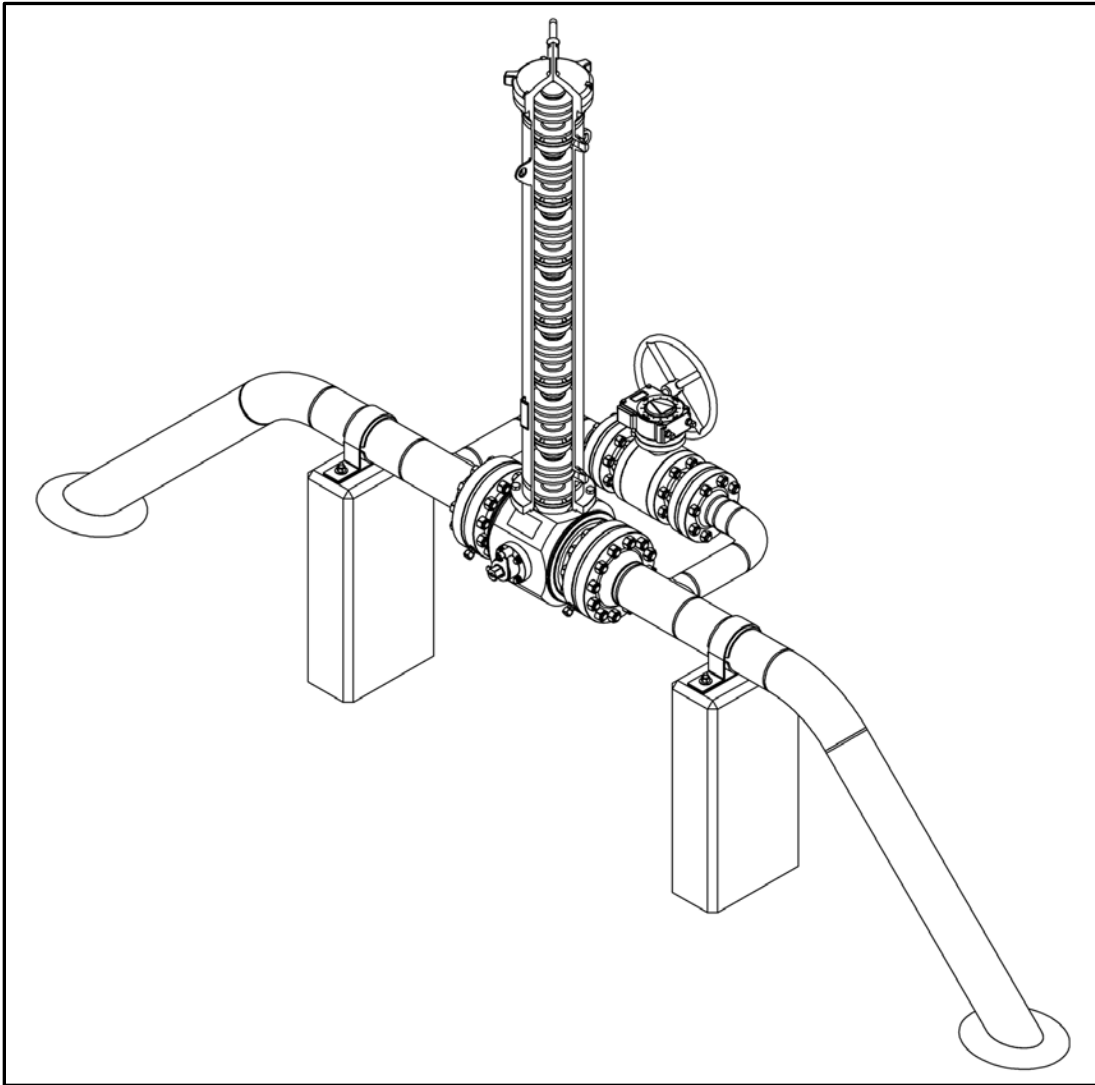

Figure 16 - Basic Configuration for Argus' Multiple Pig Launcher

Conclusion

The pigging of previously unpiggable pipelines presents a compelling challenge that demands innovative solutions. These solutions can include specific design features on pigs used to navigate traditionally unpiggable features or potential updates to line infrastructure to eliminate unpiggable geometry. The operational considerations in pigging previously unpiggable pipelines underscore the need for a complete approach. From addressing challenges in data collection and modifying existing pipelines to ensuring environmental sustainability and implementing innovative alternatives, a well-coordinated strategy is essential for successfully pigging pipelines that were once deemed unpiggable. This strategy may necessitate non-traditional launching and receiving methods such as pigging valves or implementing automated multi-pig launching to address specific operational, cost, or environmental concerns. By understanding the complexities associated with pigging, pipeline operators and industry professionals can make informed decisions to effectively address the unique requirements of pigging previously unpiggable pipelines, ensuring the continued safe and efficient transportation of vital fluids in our modern infrastructure.

References

- [1] US Department of Transportation, "Pipeline Basics," 2019. [Online]. Available: <https://primis.phmsa.dot.gov/comm/PipelineBasics.htm>.
- [2] V. Zaman and P. Dsouza, "Pioneering Approaches for Integrity Assessment of Multiphase - Difficult to Pig - Subsea Pipelines," *Inspection Engineering Journal*, no. May/June, 2015.
- [3] Interstate Natural Gas Association of America, "Report to the National Transportation Safety Board on Historical and Future Development of Advanced In-Line Inspection Platforms for Use in Gas Transmission Pipelines," 2012.
- [4] U.S. Department of Transportation, Pipeline and Hazardous Materials Safety Administration (PHMSA), "New Federal Regulations Add More Than 400,000 Miles of "Gas Gathering" Pipelines Under Federal Oversight," 15 November 2021. [Online]. Available: <https://www.phmsa.dot.gov/news/new-federal-regulations-add-more-400000-miles-gas-gathering-pipelines-under-federal-oversight>. [Accessed 21 November 2023].
- [5] U.S. Department of Transportation, Pipeline and Hazardous Materials Safety Administration (PHMSA), "New Rule Strengthens Safety Requirements for more than 300,000 miles of Natural Gas Pipelines," 4 August 2022. [Online]. Available: <https://www.phmsa.dot.gov/news/phmsa-final-rule-safety-gas-transmission-pipelines-repair-criteria-integrity-management-Improvements-cathodic-protection-management-of-change-and-other-related-amendments>. [Accessed 28 December 2023].
- [6] M. F. e. Castro, "The COVID Retirement Boom," 15 October 2021. [Online]. Available: <https://research.stlouisfed.org/publications/economic-synopses/2021/10/15/the-covid-retirement-boom>. [Accessed 5 December 2023].
- [7] H. V. Jim Cordell, Pipeline Pigging Handbook, Third Edition, Houston, TX: Clarion Technical Publishers and Scientific Surveys Ltd., 2003, pp. 3-4, 3-5, 10-5.
- [8] World Pipelines, "The rise of HDPE pipes," 29 December 2023. [Online]. Available: <https://www.worldpipelines.com/business-news/29122023/the-rise-of-hdpe-pipes/>. [Accessed 3 January 2024].
- [9] A.hak Industrial Services, Rosen Group, "Ultimate Guide to Unipiggable Pipelines," Pipelines International, 2013.
- [10] J. H. E. C. N. B. B. E. C. Sanya Singh, "Advancements in Pigging Valve & Ultrasonic Tool Technologies Allow for In-Line Inspections of Formerly Unpiggable Lines," Andeavor Logistics, Quest Integrity, La Palma, CA; Kent, WA, 2018.
- [11] Rosen Group, "Tailored for Access and Performance, Ultra-compact solution for small diameter flowlines," Rosen Swiss AG, Stans, 2017.
- [12] C. J. Steve Banks, "Non-Traditional Approaches for Internal Inspection of Any Pipeline," in *"Unpiggable" Pipeline Solutions Forum*, Houston, 2017.
- [13] Apache Pipeline Products, "Approximate Pressures and Flows Suggested for Pigging," May 2014. [Online]. Available: <https://www.apachepipe.com/assets/foam-pressures-and-flow.pdf>. [Accessed 10 January 2024].
- [14] Apache Pipeline Products, "Durometer," 05 2014. [Online]. Available: <https://www.apachepipe.com/assets/definition-of-a-durometer.pdf>. [Accessed 10 January 2024].
- [15] United States Environmental Protection Agency, "EPA Observes Air Emissions from Natural Gas Gathering Operations in Violation of the Clean Air Act," 2019.
- [16] National Energy Board, "Canada's Energy Future 2018 Natural Gas Liquids Supply and Disposition," National Energy Board, 2018.

- [17] U.S. Department of Transportation, “Gas Gathering Fact Sheet,” 2 May 2022. [Online]. Available: <https://www.phmsa.dot.gov/pipeline/gas-gathering/gas-gathering-fact-sheet>. [Accessed 21 November 2023].
- [18] 116th Congress, “Title I - Improving Pipeline Safety and Infrastructure,” 6 August 2020. [Online]. Available: <https://www.congress.gov/bill/116th-congress/senate-bill/2299/text#toc-idc845f03adf6142158d3f40c117340083>. [Accessed 22 November 2023].
- [19] C. Freeman, “A Tale of Three Pigs,” *Institute of Chemical Engineers - Loss Prevention Bulletin 190*, pp. 3-6, 2006.
- [20] Energy Safety Canada, “Occupational Fatalities in the Oil & Gas Industry in Western Canada (AB, BC & SK) - 2001 to 2020,” Energy Safety Canada, 2021.
- [21] Forbes, “U.S. Natural Gas Production Sets New Record High,” 30 August 2023. [Online]. Available: <https://www.forbes.com/sites/rrapier/2023/08/30/us-natural-gas-production-sets-new-record-high/?sh=685de9fe19a2>. [Accessed 4 January 2024].
- [22] ARGUS, “Multi-Pig Launchers (Pig Frequently, Pig Efficiently),” [Online]. Available: <https://www.argusinnovates.com/products/view-product/multi-pig-launchers>. [Accessed 10 January 2024].